

Save This Manual
For Future Reference

owner's manual

MODEL NO.
509347

509347 FITS THE
FOLLOWING RADIAL
SAWS:

113.19930, 113.197731,
113.197732, 113.199350

FOR YOUR SAFETY:

READ ALL
INSTRUCTIONS
CAREFULLY

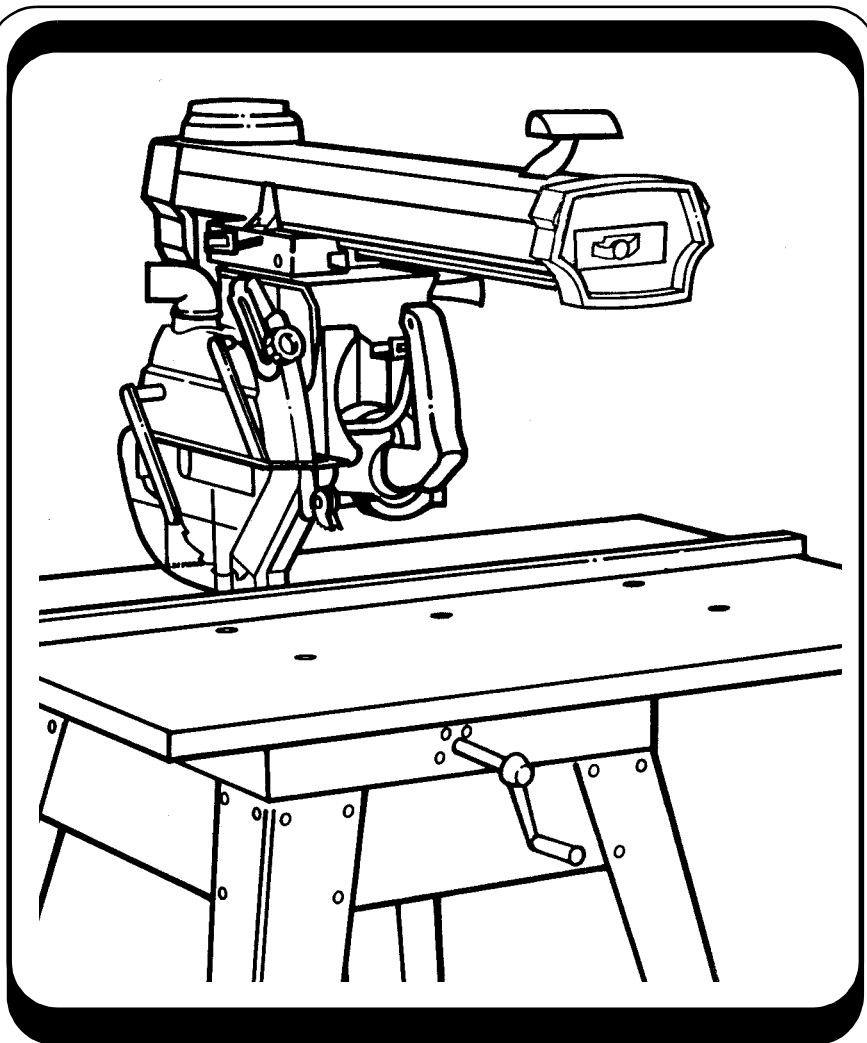

CRAFTSMAN®

10-INCH RADIAL SAW GUARD KIT

- assembly
- operating
- repair parts

Table of Contents

Section Title	Page
Table of Contents	2
Safety	3
Assembly	12
Adjustments	15
Alignment	18
Controls	23
Crosscutting	28
Ripping	32
Cutting Aides	41
Maintenance	44
Repair Parts	45

NOTE:

1. This manual is intended to be used along with your original saw manual. If you no longer have your saw's owners manual, call customer service at 1-800-325-1184. Have your saw's model number when you call.

2. If you require this manual in Spanish or French, call 1-800-511-2628.

Si usted requiere que éste manual usuario en español o francés, llame 1-800-511-2628. Pedir formulario SP5984S-2.

Si vous nécesstent ce mode d'emploi en espagnol ou français, téléphonez au 1-800-511-2628. Demander pour forme SP5984F-2.

This manual has safety information and instructions to help users eliminate or reduce the risk of accidents and injuries, including:

1. Severe cuts, and loss of fingers or other body parts due to contact with the blade.
2. Eye impact injuries and blindness, from being hit by a thrown workpiece, workpiece chips or pieces of blade.
3. Bodily impact injuries, broken bones and internal organ damage from being hit by a thrown workpiece.
4. Shock or electrocution.
5. Burns.

Major Hazards

Three major hazards are associated with using the radial arm saw for ripping. They are outfeed zone hazard, kickback and wrong way feed.

This section only briefly explains these hazards. Read the ripping and crosscutting safety sections for more detailed explanations of these and other hazards.

Outfeed Zone Hazard

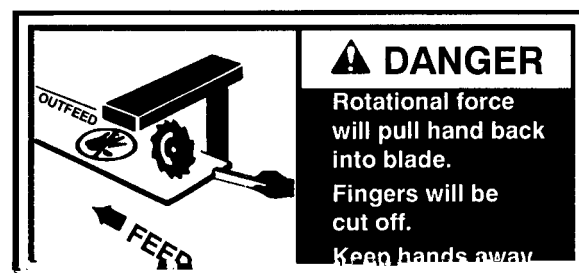

Safety Symbol and Signal Words

An exclamation mark inside a triangle is the safety alert symbol.

It is used to draw attention to safety information in the manual and on the saw. It is followed by a signal word, DANGER, WARNING or CAUTION, which tells the level of risk:

⚠ DANGER: means if the safety information is not followed someone **will** be seriously injured or killed.

⚠ WARNING: means if the safety information is not followed someone **could** be seriously injured or killed.

⚠ CAUTION: means if the safety information is not followed someone **may** be injured.

Read and follow all safety information and instructions.

If you reach around the blade to the outfeed side when ripping, and try to hold down or pull the workpiece through to complete a cut, the rotational force of the blade will pull your hand back into the blade.

Fingers will be cut off.

Read and follow the information and instructions under ripping safety.

Safety

Kickback Hazard

Kickback is the uncontrolled propelling of the workpiece back toward the user during ripping.

The cause of kickback is the binding or pinching of the blade in the workpiece. Several conditions can cause the blade to bind or pinch.

When a workpiece kicks back, it could hit hard enough to cause internal organ injury, broken bones, or death.

Read and follow the information and instructions under ripping safety.



Wrong Way Feed Hazard

Wrong way feed is ripping by feeding the workpiece into the outfeed side of the blade.

The rotational force of the blade can grab and pull the workpiece.

Before you can let go or pull back, the force could pull your hand along with the workpiece into the blade. Fingers or hand could be cut off.

The propelled workpiece could hit a bystander, causing severe impact injury or death.

Read and follow the information and instructions under ripping safety.



Guard Function and Features

The guard is a very important safety feature, designed to reduce the risk of injury associated with blade contact. **Install the guard correctly. Follow the specific instructions in the ripping and crosscutting sections to set and use the guard correctly for each type of cut.**

Guard Features Include:

1. A non-moveable **metal upper portion**, (Upper Guard) which is fastened to the motor by the guard clamp screw, and which fully covers the upper half of the blade.
2. A moveable **clear plastic portion**, (Plastic Lower Guard) which partially covers the lower half of the blade. It protects against contact with the side of the blade during crosscutting when blade is in its rearmost position and the guard is resting on the table, so the leading and trailing teeth of the blade are not exposed. It also protects against contact with the outfeed side of the blade during ripping, and acts as a barrier to prevent wrong way feed.
3. A **squeeze trigger** in the saw handle to fully raise the clear plastic guard at the start of a crosscut. **Note:** *This is necessary because the guard will not automatically raise to clear the fence.*
4. A **hold down** to be lowered to just clear the top of the workpiece for ripping. It acts as a barrier to the infeed side of the blade, keeps the workpiece from fluttering, and acts as a sawdust deflector. It is locked/unlocked by the hold down knob.
5. A **ripping knife** to be lowered to the table for ripping. It keeps the workpiece kerf open, thereby reducing blade pinching and the risk of kickback. It also acts as a barrier to the hazardous outfeed side and prevents wrong way feed. It is locked/unlocked by the ripping knife/pawls knob. When lowered for cross-cutting, it acts as a barrier to the leading edge of the blade.

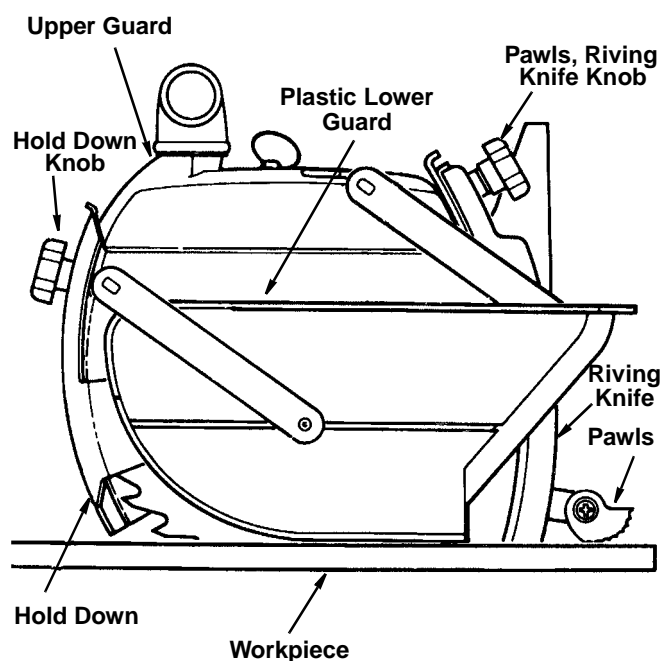
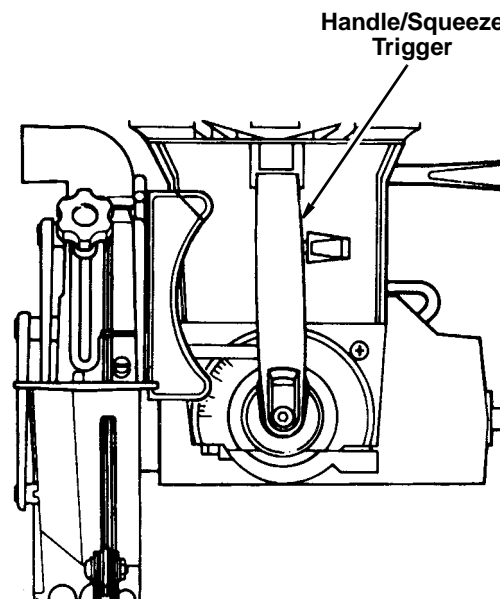

Safety

6. Set of **pawls** to be lowered to the work-piece surface for ripping. They allow the workpiece to pass freely from infeed to out-feed side, but help stop the kickback motion from outfeed to infeed side by grabbing into the workpiece surface. **Pawls** must be reset each time a different thickness workpiece is cut.

7. A **guard tab** to manually raise the plastic guard at the start of ripping unusual work-pieces whose size/shape do not cause the guard to raise automatically.

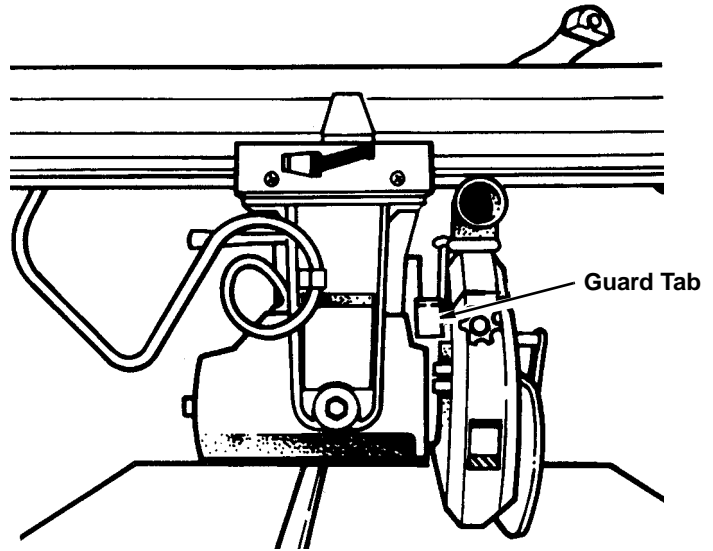

Hazards Associated with Clear Portion of Guard

The following safety information applies to all blades and accessories.

WARNING

Clear plastic portion of guard will not provide any protection during cross-cutting if blade is pulled over your hand, or your hand enters blade path from front or rear of blade. Fingers or hand can be cut or cut off.

CAUTION

Clear plastic portion of guard can get caught or jam in fence or table kerfs. Read and follow the warning on the guard:



WARNING:
TO AVOID INJURY
SHUT OFF POWER
BEFORE CLEARING A
JAMMED LOWER GUARD



WARNING

Clear plastic guard will increase risk of certain hazards:

- During rip and bevel cuts, narrow cut off pieces can be pinched between guard and blade. Cut-off pieces can kickback.
- In bevel position blade teeth are fully exposed. Fingers or hand can be cut off.

- Cut-off pieces can jam between guard and blade. Turn saw off and wait for blade to stop before freeing jammed guard or blade.
- Workpiece or cut-off pieces can be violently thrown by blade. Wear safety goggles. Stand out of workpiece path.

Safety Instructions

Read and follow all safety instructions.

Personal Safety Instructions

1. Wear safety goggles labeled ANSI Z87.1 (or in Canada CSA Z94.3-99) on the package. It means the goggles meet impact standards set by the American National Standards Institute. Regular eyeglasses are not safety goggles.
2. Wear close fitting clothes, short sleeved shirts, and non-slip shoes. Tie up long hair. Do not wear gloves, ties, jewelry, loose clothing, or long sleeves. These can get caught in the spinning blade and pull body parts into the blade.
3. Wear dust mask to keep from inhaling fine particles.
4. Wear ear protectors, plugs or muffs if you use saw daily.
5. Keep good footing and balance; do not over-reach.

Work Area Safety Instructions

1. Keep children, pets, and visitors out of work area; they could be hit by a thrown workpiece, workpiece chips or pieces of blade.
2. Turn saw off, remove yellow key, and unplug before leaving work area. Do not leave until blade has stopped spinning.
3. Make work area child-proof: remove yellow key to prevent accidental start-up; store key out of sight and reach; lock work area.
4. Keep floors clean and free of sawdust, wax and other slippery materials.
5. Keep work area well lighted and uncluttered.
6. Use saw only in dry area. Do not use in wet or damp areas.

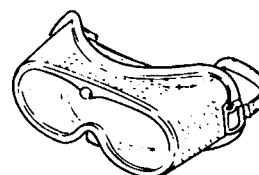

Safety Goggles

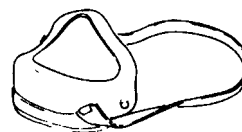

Dust Mask

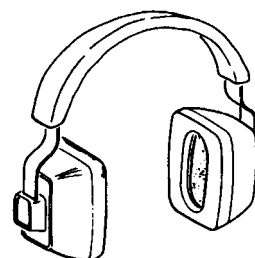

Ear Protectors

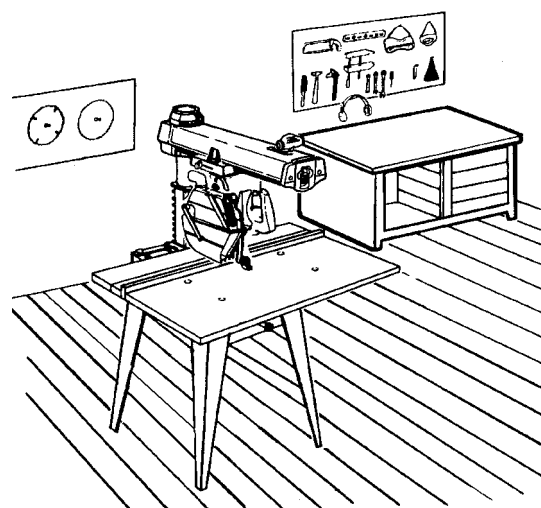

Safety

Saw Safety Instructions

1. Use guard, pawls and riving knife according to instructions. Keep them in working order.
2. Routinely check saw for broken or damaged parts. Repair or replace damaged parts before using saw. Check new or repaired parts for alignment, binding, and correct installation.
3. Unplug saw before doing maintenance, making adjustments, correcting alignment, or changing blades.
4. Do not force saw. Use saw, blades and accessories only as intended.
5. Have yellow key out and saw switched off before plugging in power cord.

6. Before turning on saw, clear table of all objects except workpiece to be cut and necessary fixtures, clamps, or feather-boards.
7. If blade jams, turn saw off immediately, remove yellow key, then free blade. Do not try to free blade with saw on.
8. Turn saw off if it vibrates too much or makes an odd sound. Correct any problem before restarting saw.
9. Do not layout, assemble, or setup work with saw on, or while blade is spinning.
10. Keep saw table clean.
11. Store items away from saw. Do not climb on saw or stand on saw table to reach items because saw can tip over.

Workpiece Safety Instructions

1. Cut only wood, woodlike or plastic materials. Do not cut metal.

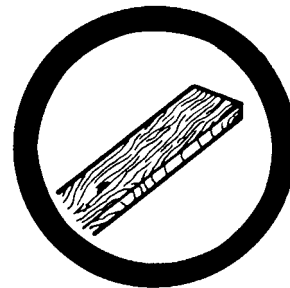

2. Cut only one workpiece at a time. Stacking or placing workpieces edge to edge can cause user to lose control of workpiece.

3. Rip only workpieces longer than the diameter of the blade. Do not rip workpieces that are shorter than the diameter of the blade being used.

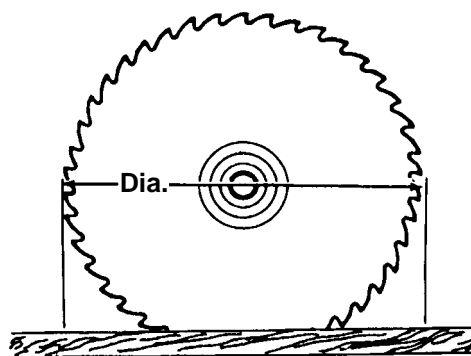

4. Workpieces that extend beyond the saw table can shift, twist, rise up from the table, or fall as they are cut or afterwards. Support workpiece with table extensions the same height as the saw table.

5. To prevent tipping, support outer ends of extensions with sturdy legs or an outrigger.

6. Do not use another person to help support workpieces or to aid by pushing or pulling on workpieces, because these actions can cause kickback. Use table extensions.

7. Use clamps or vice to hold workpiece. It's safer than using your hands.

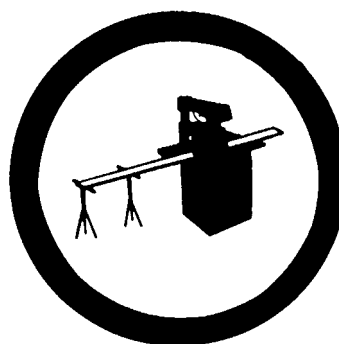

Blade Safety Instructions

1. Use only blades marked for at least 3450 rpm.
2. Use only 10" or smaller diameter blades.
3. Use blades for their recommended cutting procedures.
4. Keep blade sharp and clean.

5. Do not overtighten blade nut because blade collar could warp.

6. Do not turn saw on and off in rapid sequence because blade can loosen.

7. Blade should stop within 15 seconds after saw is switched off. If blade takes longer, the saw needs repair. Contact Authorized Service Center.

Safety

On-Product Safety Labels

There are several safety labels on the saw. They alert the user to hazards explained in the manual and remind the user how to avoid the hazard.

At the **outfeed side**, to the right of the **guard** near the saw handle is this safety label to alert you to **wrong way feed**:

On the **infeed side** of the **guard** is this safety label to remind you to **lower the hold down** to just clear the top of the **workpiece** for **ripping**:

On the **rear of the yoke**, visible from the infeed side when the saw is in a rip position, is this safety label to alert you to **outfeed zone hazard**:

Note where they are located on the saw. Read and follow the safety information and instructions in these labels. Refer to the manual for detailed explanations and instructions.

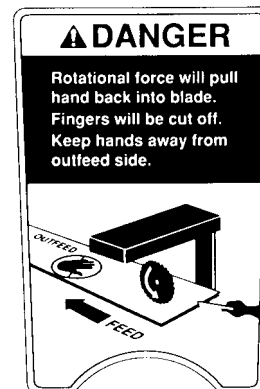
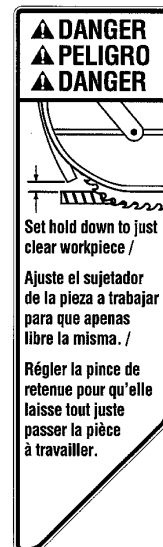
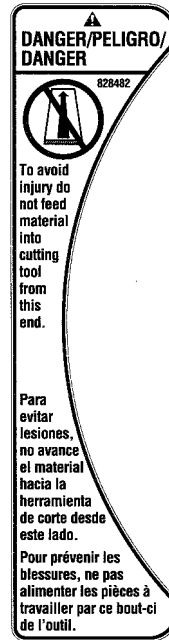

Near the saw handle is this safety label to alert you to **thrown objects** and to remind you to **wear safety goggles**:



On the **clear plastic guard** is this OSHA required label:

▲ WARNING / ADVERTENCIA / AVERTISSEMENT		
To avoid injury shut off power before clearing a jammed lower guard	Para evitar lesiones, apague la sierra antes de desatascar un protector inferior atascado	Pour prévenir les blessures, couper l'alimentation avant de libérer toute obstruction du guide inférieur.

On the **bottom surface of the motor**, visible when the cutting tool is horizontal, is this safety label alerting you to **use a guard when edge molding**, and to **position the cutting tool behind the fence**:

(see Accessories Section)

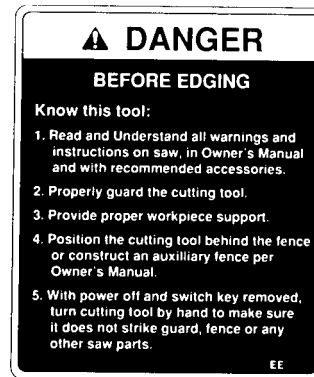

On the **front of the yoke** is this **general safety** instruction label:

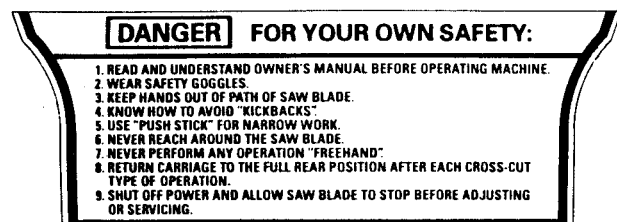

Assembly

Identify Parts

The following parts are included:

Note: Before beginning assembly, check that all parts are included. If you are missing any part, do not assemble guard. Contact Emerson Tool Co. Service Center at 1-800-325-1184 to get the missing part. Sometimes small parts can get lost in packaging material. Do not throw away any packaging until guard is put together. Check packaging for missing parts before contacting Emerson Tool Co. A complete parts list (Repair Parts) is at the end of the manual. Use the list to identify the number of the missing part.

List of loose parts with model 509347

A. Guard Assembly	1
B. Rear Table 40"	1
C. Spacer Table 40"	1
D. Front Table 40"	1
E. Table Support	2
F. Handle Assembly.....	1
G. Bag of Loose Parts	1
Containing:	
H. Table Clamp Asm.....	2
I. Tee Nut	1
J. Bag of Loose Parts	1
Containing:	
K. Guard Accessory	1
L. Screw Plastite #8 x 1/2	1
M. Washer 3/16 x 1 x 1/16.....	1
N. Instruction Form.....	1

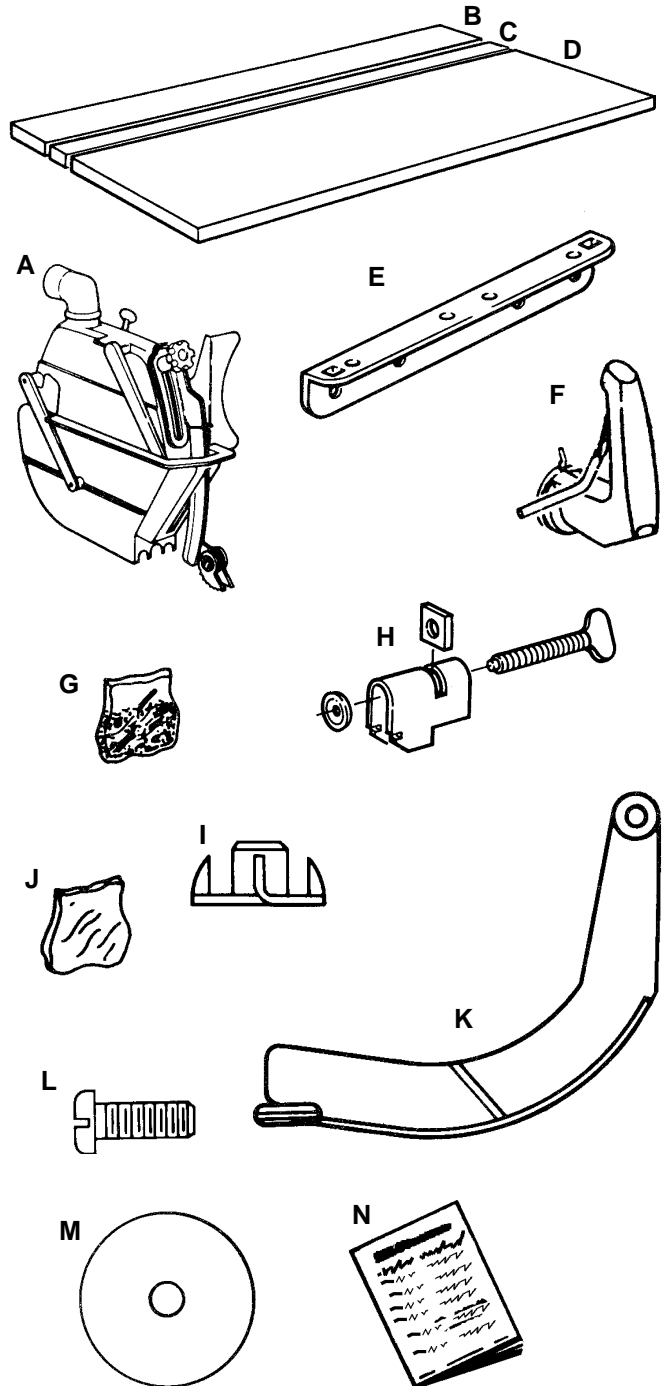

WARNING

Plugging in saw during assembly could result in electrical shock, or severe cuts from contact with spinning blade.

Do not plug in saw at any time during assembly.

Plug in saw only when it is to be used.

Remove Sawblade and Guard

1. Tighten carriage lock knob.
2. Loosen guard clamp screw, remove guard.
3. Motor shaft has left hand threads. Hold shaft wrench and rotate arbor wrench down (clockwise).
4. Remove shaft nut, outer collar, sawblade, and inner collar. Dispose of guard but retain shaft nut, outer collar sawblade and inner collar.

Remove Original Table Boards, and Mounting Supports

NOTE: All original hardware (except for T-Nut) will be required for mounting retrofit parts.

1. Loosen the table clamps and remove the rear table, spacer table and rip fence. Discard the rear table and spacer table. Save the fence, it will be reused.
2. Remove the 1/4-20 x 1" cup point screw from the T-Nut located in the front table. Retain this screw for future use.
3. Remove all remaining nut, bolts, and washers and lift off front table. Discard the front table.
4. Remove nuts, bolts and washers that secure the left and right table support channels. Discard the support channels.

WARNING

This retro fit guard kit required additional clearance behind fence. New table boards are being supplied for this reason.

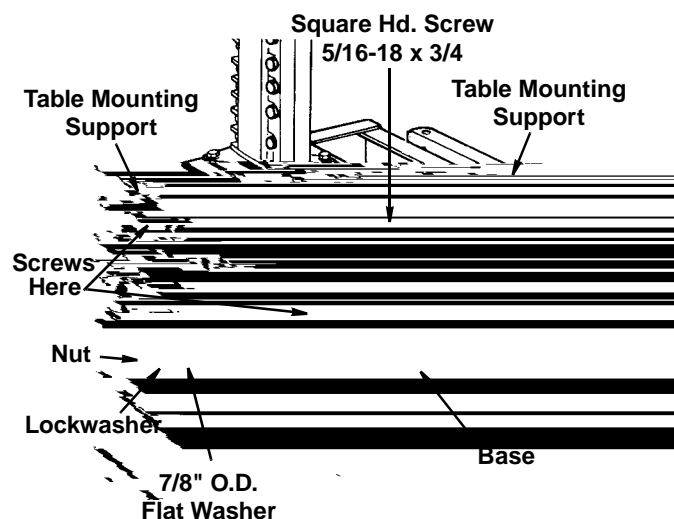
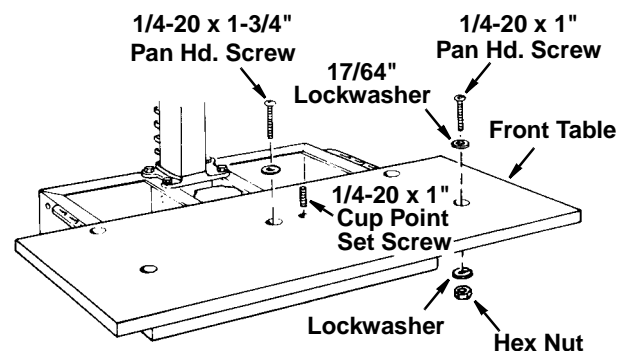
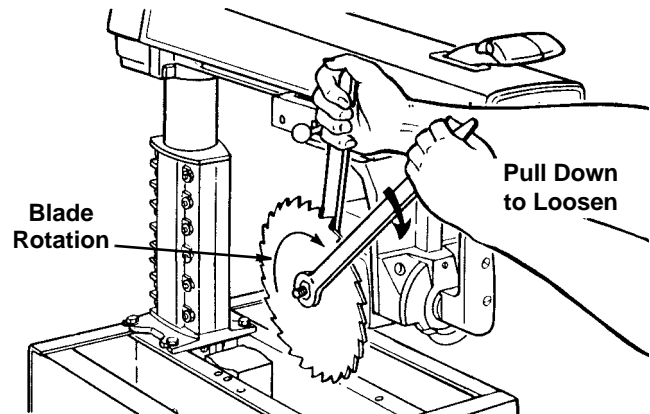

Assembly

Attach new table supports

1. Set out:
 - two table supports
 - four 5/16" 18 x 3/4" long square head screws
 - four 11/32" x 7/8" x 1/16" flat washers
 - four 5/16" lockwashers
 - four 5/16" hex nuts
 - Attach supports to side frame, making sure to use correct holes in table supports and side frame: Use two screws per support (insert screws through base and then support); on end of each screw put a flat washer, lockwasher and nut, then finger tighten to table supports rest in lower position.

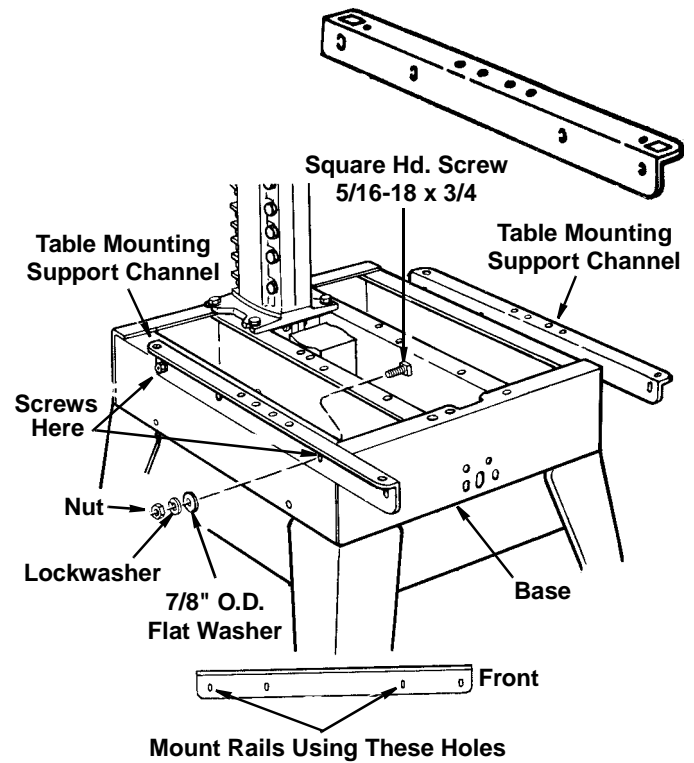

Positioning Table supports/Installing Front Table/Leveling Front Table

NOTE: The goal in adjusting the table supports and leveling the front table is to make sure that the table is the same distance from the radial arm at all points. This ensures that when the table and blade are installed the clearance between them will be equal at all points.

Positioning Table Supports

1. Release bevel lock lever, move bevel index lever to the left and rotate the motor to position arbor shaft down. Lock bevel lock.
2. Unlock and hold miter/arm lock lever in index release position as shown. Position arm against left stop (approximately 50° miter). Loosen carriage lock knob and position arbor shaft directly over left hand channel.

NOTE: For safety reasons in accordance with the UL standard, stops have been provided to prevent 360° rotation of the radial arm.

3. Slide the arbor wrench handle between end of motor shaft and table support to act as a feeler gauge. Carefully lower the motor with elevation crank until the end of shaft is just touching the arbor wrench. The wrench should slide back and forth with only slight resistance. Tighten screw "A".

NOTE: Do not change this elevation setting until both left and right hand table support channels have been adjusted.

4. Move arm and carriage to screw "B". Adjust position of table support so that the arbor wrench just slips between the end of the motor shaft and the support. Tighten screw "B".
5. Move arm and carriage to right hand table support and level in the same manner as in step 4.
6. Recheck both support channels to make sure that tightening screws did not affect the accuracy of the adjustment.
7. Elevate the saw and return motor to horizontal position to provide clearance for installation of front work table.

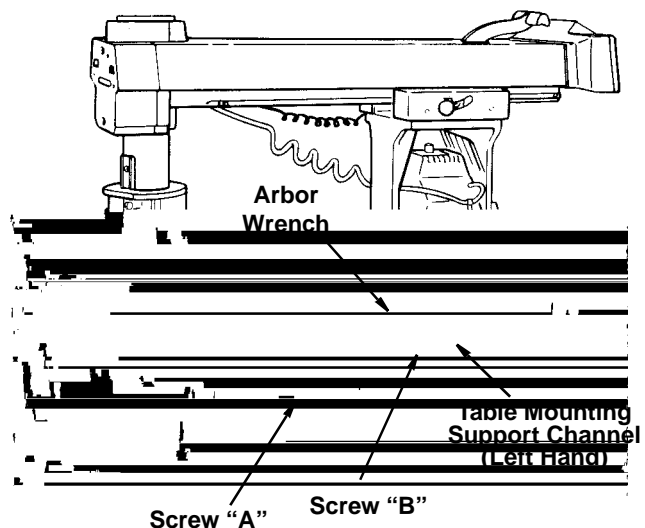
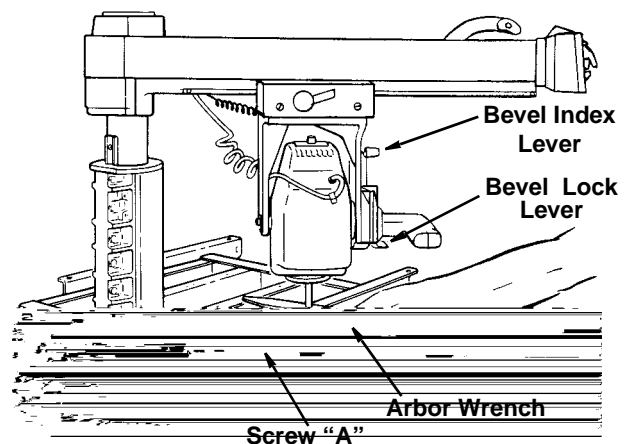
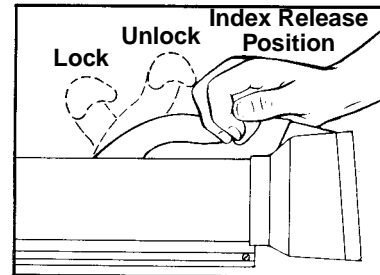

Assembly

Installing Front Table

1. Set out:

- front table
- tee nut
- 1/4" U-clip
- 1/4" diam. x 7/8" long cup point set screw
- four 1/4" diam. x 1" long pan head screws
- 1/4" dia. x 1-3/4" long pan head screw
- five 17/64" I.D. x 5/8" O.D. flat washers
- four 1/4" lockwashers
- four 1/4" diam. hex nuts

2. Identify top and bottom of table: top has counterbored holes. Place table **bottom side up** on solid surface. Hammer tee nut into leveling hole. (This hold is not counterbored from the top).

3. Snap u-clip onto front edge of base so hole lines up with hold just to the left of center notch.

4. Place table, **top side up**, on saw so center counterbored hole lines up with hole in u-clip. **NOTE:** Table will extend over front edge of saw frame.

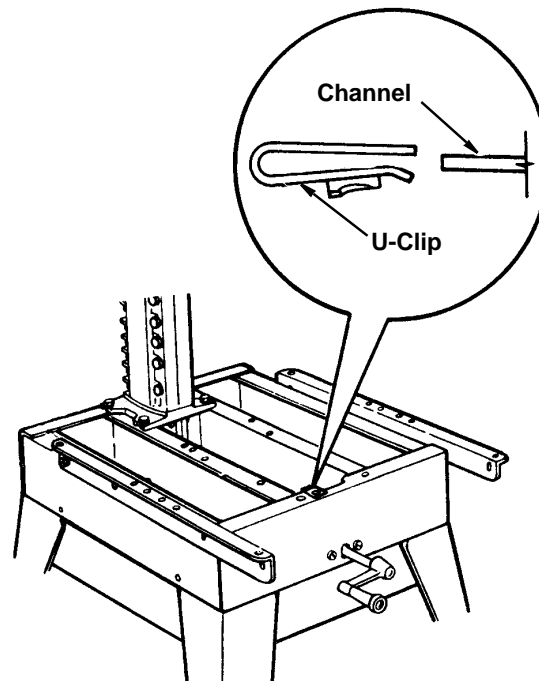
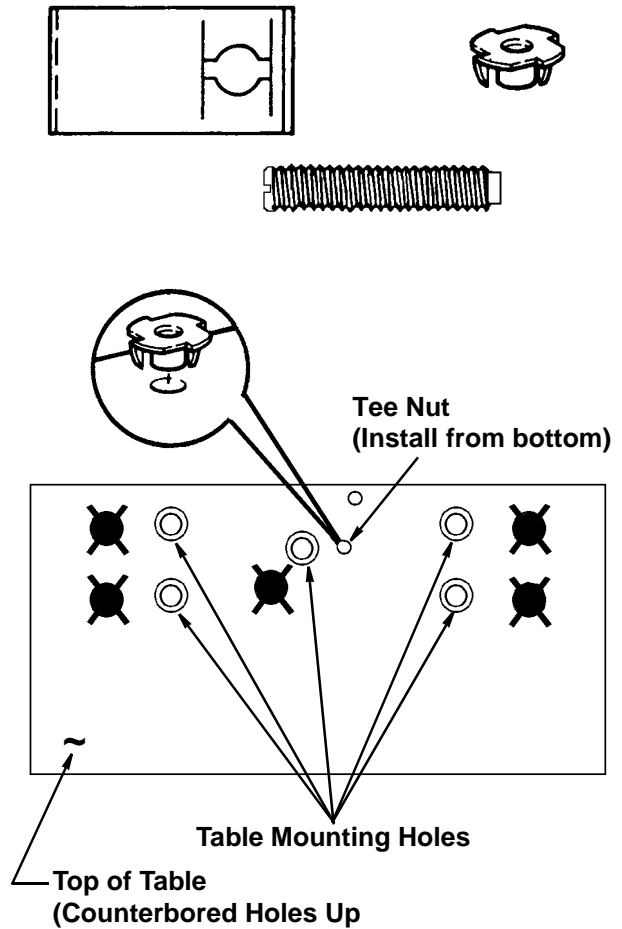

Assembly/Adjustments

- Drop a flat washer into each counter-bored hole.
- Start 1-3/4" long pan head screw through center hole and into U-clip, but do not fully tighten.
- Start cup point set screw through leveling hole and into tee nut, but do not fully tighten.
- Put 1" long pan head screw in each of four remaining holes and through matching holes in table supports. On end of each screw, put lockwasher then nut and tighten with screwdriver.

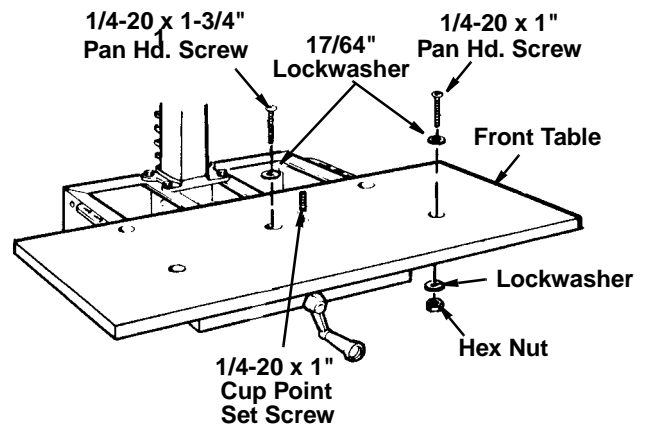

Make Front Table Flat

- Place rear table on its edge, across center of front table. Check for gap between surfaces.

If there is less than 1/32" gap, tighten cup point set screw until it touches frame (look underneath table), then tighten center (1-3/4" long pan head screw.

If there is more than 1/32" gap, close gap by raising or lowering center of front table:

to raise center, tighten cup point set screw against frame;

to lower center, tighten center (1-3/4" long) pan head screw.

- When gap is closed, make sure cup point set screw touches frame (look underneath table), and center (1-3/4" long) pan head screw is tightened.

NOTE: Rip fence scale is no longer correct. Measure distance between fence and blade for correct distance when in rip mode.

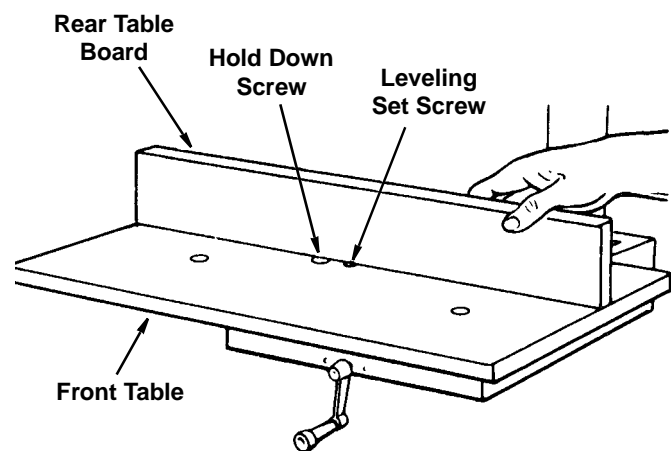

Alignment

The saw and blade must be aligned correctly for two reasons:

- 1) To prevent binding of the blade and work-piece, which can cause jams, kickbacks, or thrown workpieces;
- 2) To make accurate cuts.

Alignment and Adjustment Steps

The following alignments and adjustments **must be made in order**. If you miss an adjustment, you must go back, make the missed adjustment, and repeat all steps from that point on.

These adjustments are like fine tuning a piece of equipment. Often, a series of steps must be repeated more than once in order to get the adjustment right. There are many adjustments to make. Because some adjustments may be awkward, you may want to ask someone to help you.

Before you start, make sure the framing square is true.

Square Crosscut Travel

The goal of this adjustment is to make accurate crosscuts. To do so, the radial arm must be square to the fence, otherwise, there will be a slight miter angle in all crosscuts.

Squaring cross cut travel.

1. Index but do not lock arm at 0° miter.
2. Install saw blade as shown. Motor shaft has left hand threads.

Note: Do not overtighten arbor nut. Use the arbor wrench to just "snug" it.

WARNING

Plugging in saw during alignment could result in accidental start-up and severe cuts from contact with spinning blade. Do not plug in saw at anytime during alignment or adjustment. Plug in saw only when it is to be used.

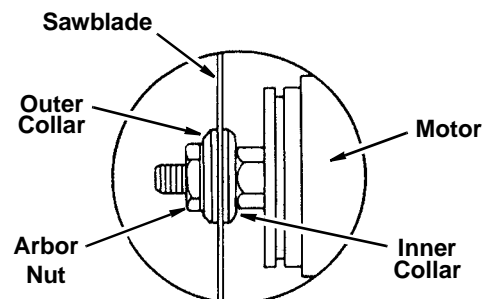
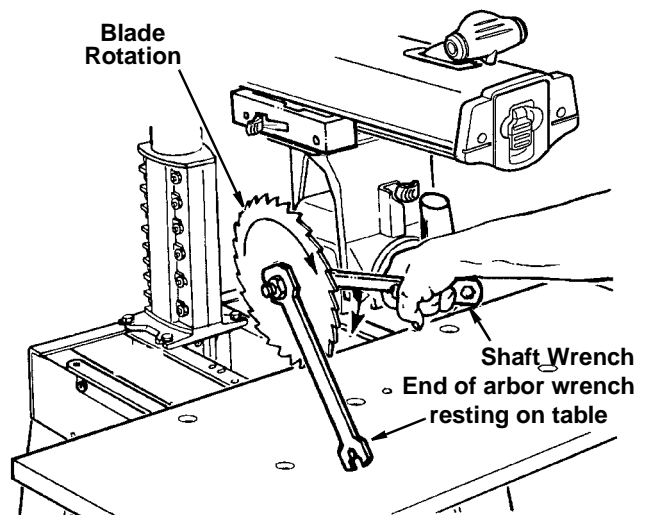
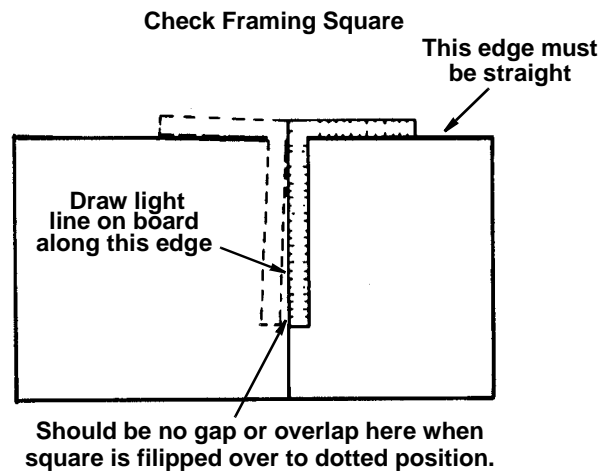

Alignment

3. Lower arm until saw blade just clears the front table. Tighten the yoke lock lever and bevel lock lever.
4. Place a framing square on the table, as shown, with one leg of square firmly against rear edge of front table. Position the blade and square until the leg of the square just contacts a tooth of the blade. Mark this tooth.
5. When the carriage is moved slowly back and forth on the arm, the marked tooth should just touch the square at all points. If marked tooth moves into or away from square, follow the adjustments as described in your saw's original owners manual. If you no longer have your saw's owners manual call Customer Service at 1-800-325-1184. Have your saw's model number ready when you call.

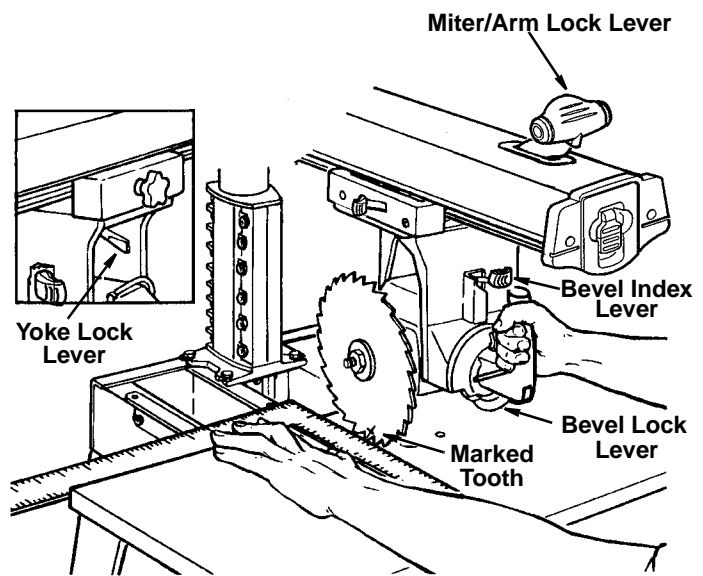

Install New Table Clamps

1. Insert fence, then spacer table, then rear table.
2. Tilt clamp forward and snap into place in opening at rear of table support.
3. Tighten thumbscrews to clamp table sections in place.

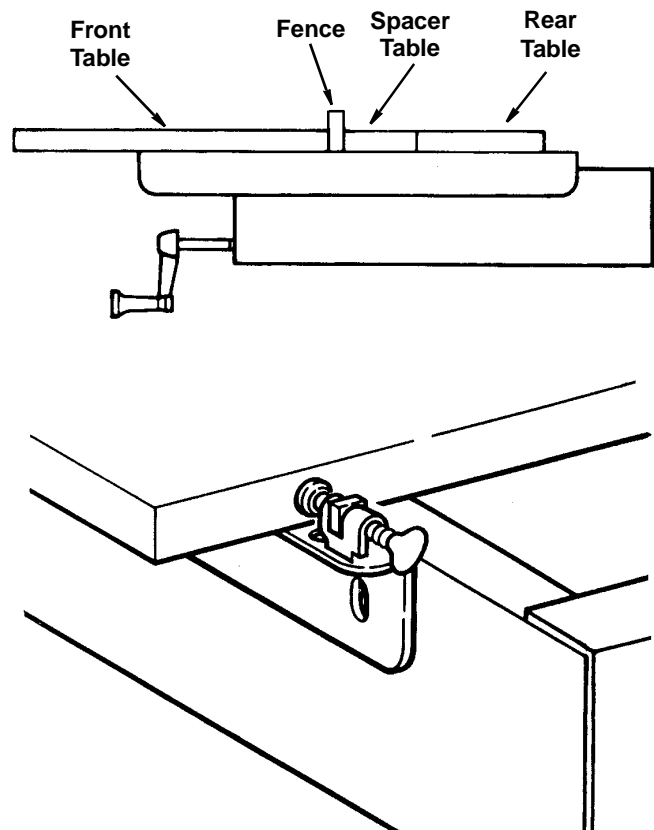

Assembly

Replacing Handle

1. Remove screw "A" from handle assembly.
2. Remove trim handle "B".
3. Remove screw "C" and lockwasher "D". Yoke handle "E" should then be removed.

4. Remove the bevel indicator and screw attached to the yoke handle ("E"). Reinstall these pieces on the new handle.

5. Attach new handle reusing screw "C" and lockwasher "D".

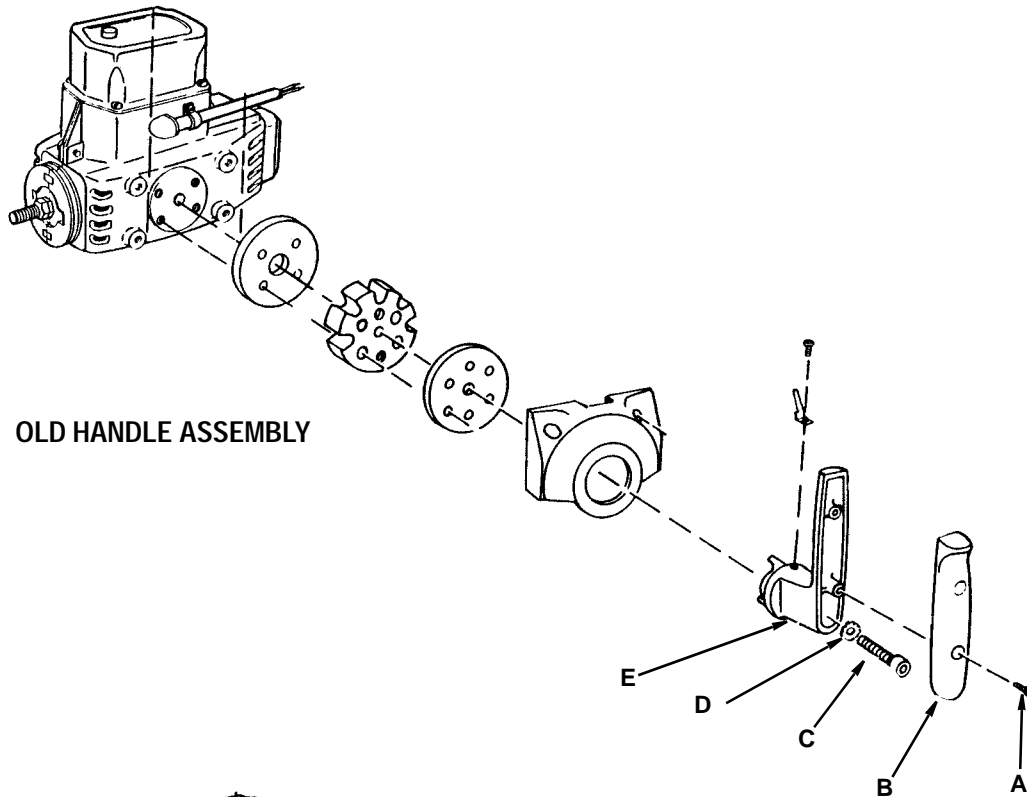

OLD HANDLE ASSEMBLY

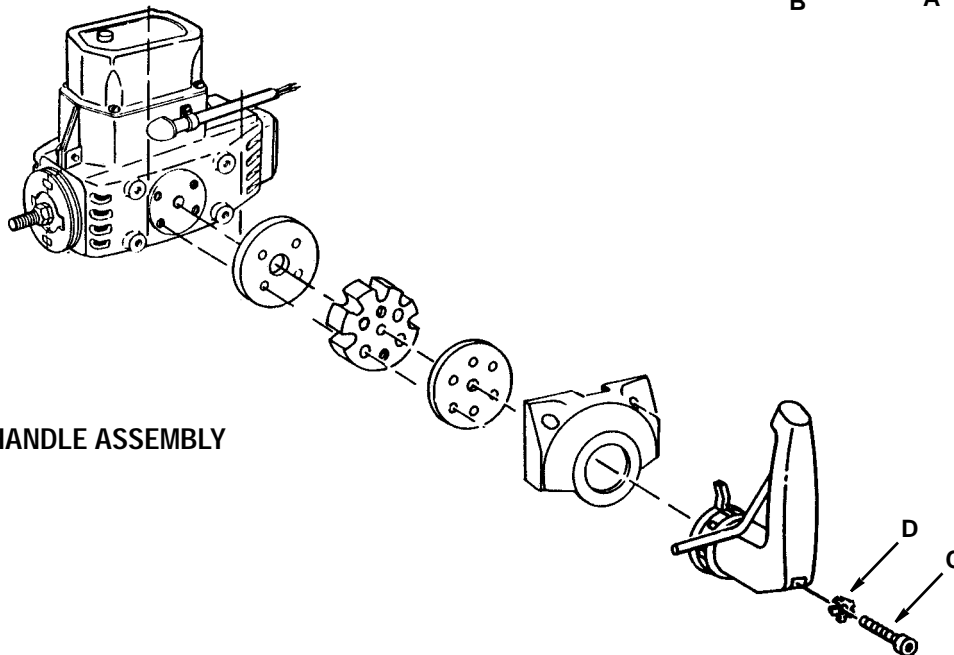

NEW HANDLE ASSEMBLY

Install Guard

The guard is a very important safety feature. It covers a large part of the blade and helps protect against severe cuts. Always use the guard

1. Lock motor at 0° bevel (blade vertical).
2. Use one hand to lift clear plastic guard; use other hand to grasp rear of guard (below dust elbow). Position guard so riving knife faces front of saw.
3. Tilt front of guard down about 45°; place over blade; rotate guard to level position.

NOTE: Make sure two screw heads on back of guard are resting on top of motor housing. This will prevent movement of guard about motor. Squeeze handle trigger to make sure it fully raises clear plastic guard. If it does not, remove and reinstall guard, making sure that trigger mechanism engages pull link on guard.

4. Tighten guard clamp screw.

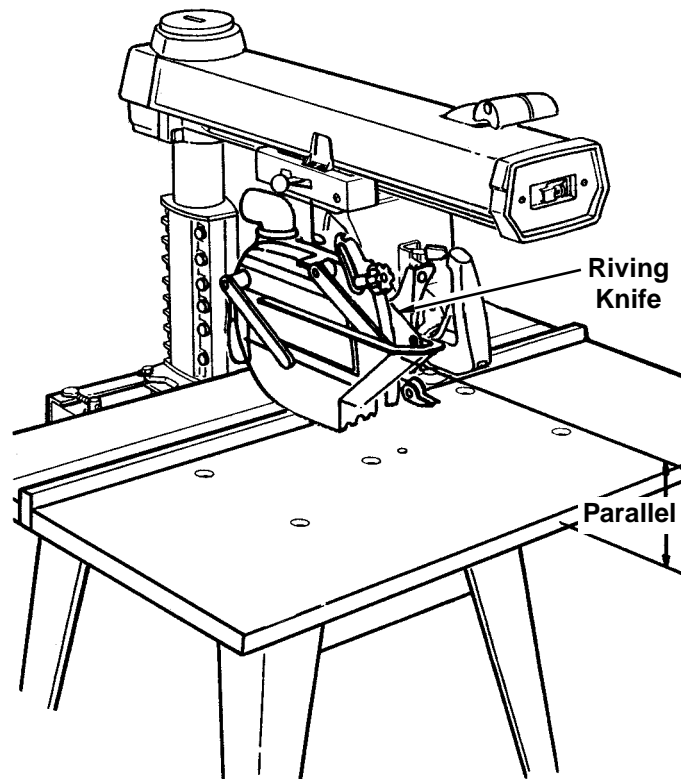

Alignment

Align Riving Knife to Blade

The goal of this adjustment is to position the riving knife directly in line with the blade.

Riving knife alignment is an important safety factor. The riving knife rides in the kerf of the cut workpiece during ripping to keep the two sides of the workpiece from pinching on the blade. Blade pinching is a cause of kickback.

1. Lock yoke in in-rip position (blade towards column, motor towards front of arm).
2. Lower arm until blade just clears table.
3. Unlock rip lock while holding up lower plastic guard, move yoke back until blade touches fence. Lock rip lock.
4. Loosen pawls/riving knife knob. Lower riving knife to the table and tighten knob. The riving knife should rest flat against fence.
5. If adjustment is needed:
 - a.) loosen riving knife bracket screw.
 - b.) slide riving knife so it rests against fence.
 - c.) secure riving knife bracket screw.
6. Raise riving knife and tighten pawls/riving knife knob.

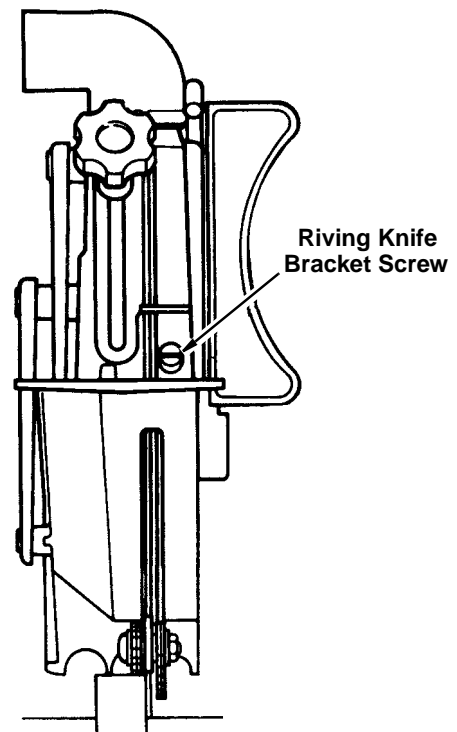
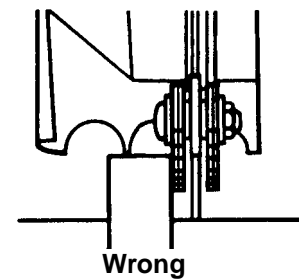
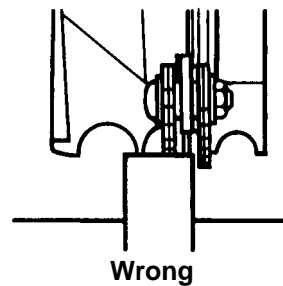
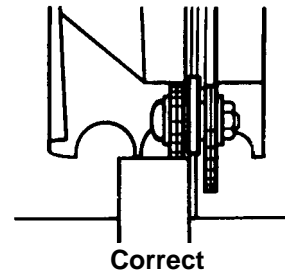

Controls

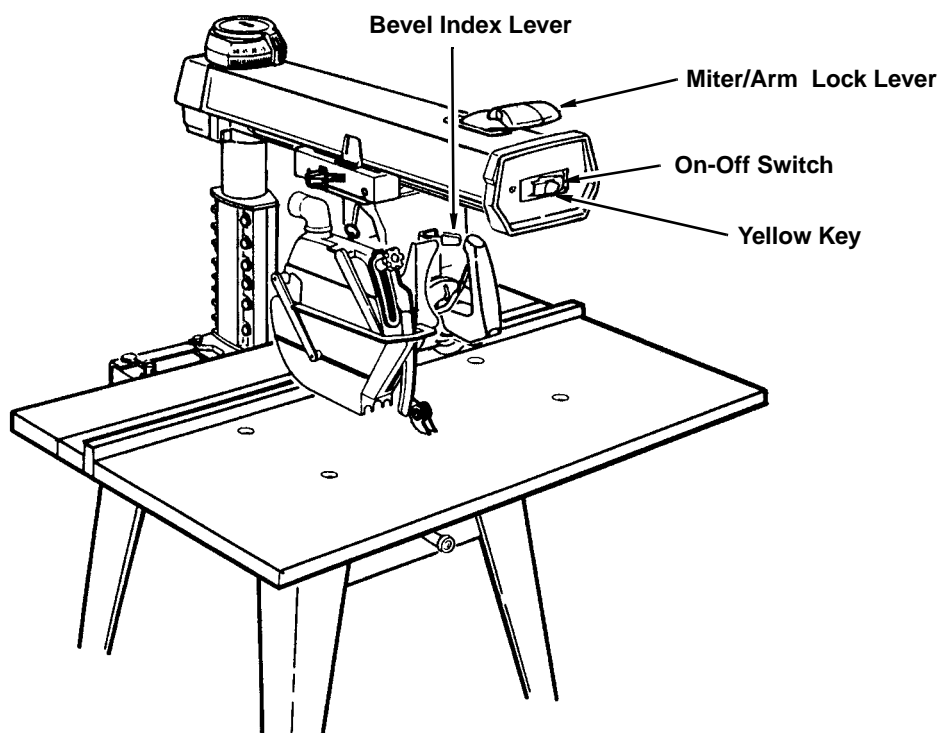

<u>Control</u>	<u>Function</u>	<u>Operation/Comments</u>
Miter/Arm Lock	Frees radial arm to move; locks in any desired position; pre-set indexed positions at 0°, 45°L, 45°R	Pull lever forward to release index then swing arm left or right. <i>Hold in unlocked position while moving arm</i>
On-Off Switch	Turns motor on/off	Pull on, push off <i>Requires yellow key</i>
Yellow Key	Allows saw to be switched on	Insert into on-off switch <i>Remove after turning saw off</i>
Bevel Index Lever	Indexes the sawblade to 0°, 45°, or 90° pre-set indexed positions	Move bevel index lever to the left while positioning the blade, then release it

Controls

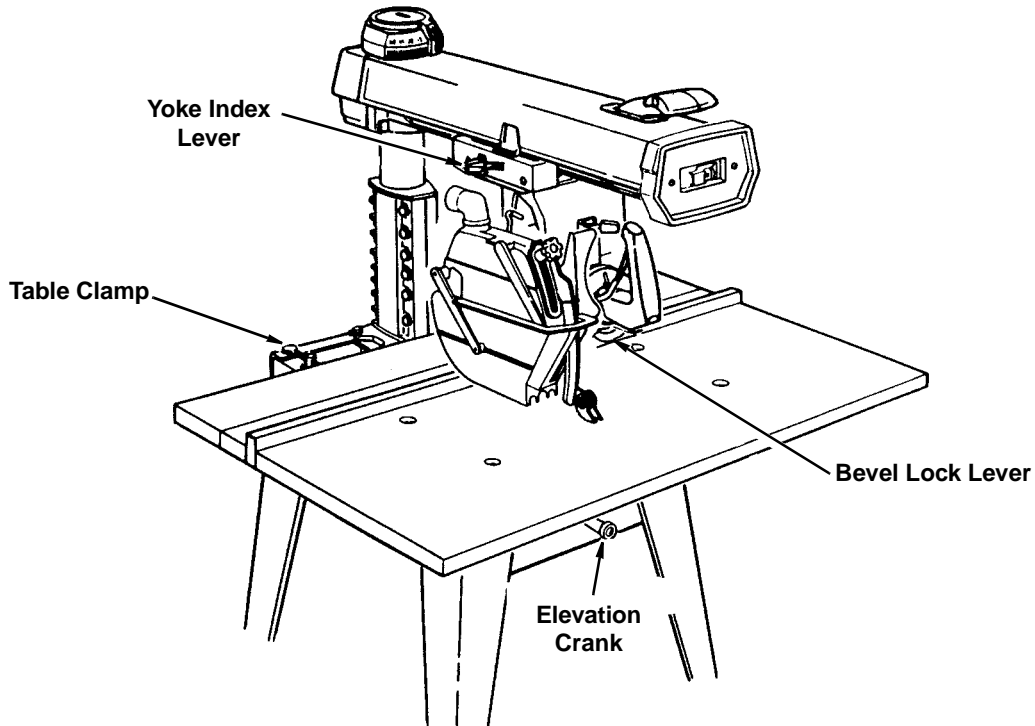

<u>Control</u>	<u>Function</u>	<u>Operation\Comments</u>
Bevel Lock Lever	Frees motor to rotate; locks in any desired position	Pull lever to release and push to lock <i>Support motor before unlocking because it can swing down quickly</i> <i>Bevel index lever must be unindexed before moving motor</i>
Elevation Crank	Raises/lowers radial arm	Turn clockwise to raise, counterclockwise to lower
Table Clamp	Frees table sections to allow changing fence position	Turn clockwise to tighten, counterclockwise to loosen
Yoke Index Lever	Frees yoke to rotate between rip and crosscut positions	Pull the spring loaded yoke pivot latch forward to release this pin

Controls

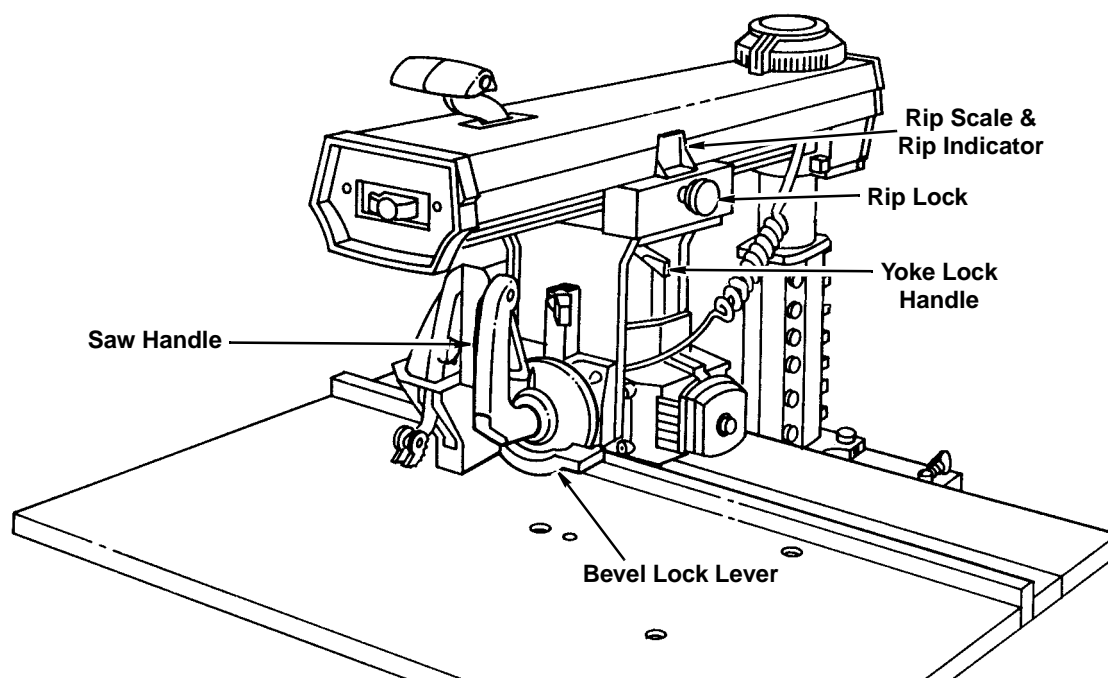

<u>Control</u>	<u>Function</u>	<u>Operation/Comments</u>
Yoke Lock Handle	Locks yoke in rip or crosscut position	Pull handle forward to release; push handle rearward to tighten <i>Yoke index lever must be unindexed before rotating yoke</i>
Rip Lock	Locks carriage to radial arm for ripping	Rotate counterclockwise to release carriage; turn clockwise to lock carriage in position <i>Lock before ripping</i>
* Rip Scale & Rip Indicators	Tells approximate distance between blade and fence when saw is in in-rip or out-rip position	Move blade carriage along arm to align line on indicator with desired number on scale
Saw Handle	Provides grasping surface so carriage can be moved. Contains trigger mechanism to raise clear plastic guard when making a crosscut	Grasp to move blade carriage <i>Squeeze trigger to fully raise clear and plastic guard. Clear guard must be raised over fence to crosscut</i>

* **NOTE:** After installing new guard and new table boards rip fence scale is no longer correct. Measure distance between fence and blade for correct distance when in rip mode.

Controls

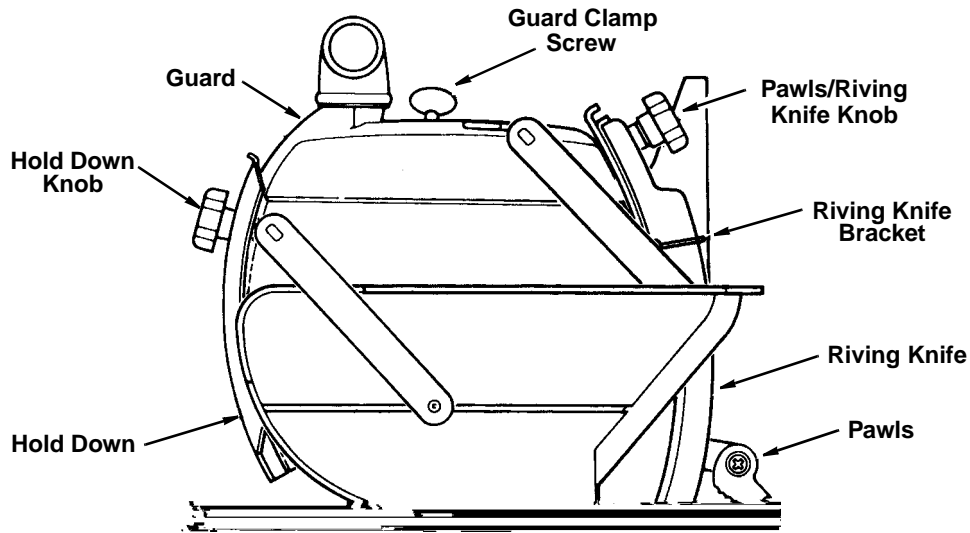

<u>Control</u>	<u>Function</u>	<u>Operation/Comments</u>
Guard Clamp Screw	Secures guard to motor; frees guard for removal	Turn counterclockwise to loosen, clockwise to tighten
Guard	Protects against contact with upper blade; partially protects against contact with lower blade; acts as sawdust deflector	Upper part remains fixed in level position. <i>Notch in guard fits securely into matching tab on motor</i> Clear guard is moveable: fully raise over fence at start of crosscut; <i>See Saw Handle</i> ; most workpieces will automatically raise clear guard during ripping; <i>See Guard Tab</i>
Hold Down Knob	Frees hold down to move up and down; locks hold down in place	Turn counterclockwise to loosen, clockwise to tighten
Hold Down	During ripping, acts as partial barrier to infeed side of blade; keeps infeed side of workpiece from fluttering; acts as sawdust deflector	For ripping, lower hold down to top of workpiece surface, then raise slightly and lock in place. For crosscutting lock in fully raised position
Riving Knife Bracket	Prevents side to side movement of riving knife and provides means for adjusting alignment	Loosen to align riving knife, then tighten

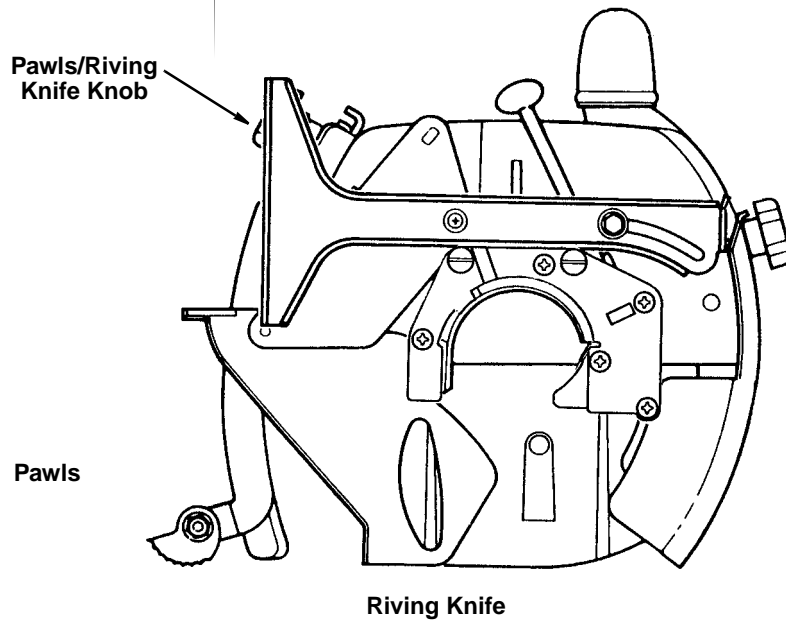

Crosscutting

Crosscutting Defined

Crosscutting is cutting a workpiece to length. The workpiece is held firmly against the fence, and the blade is pulled through the workpiece to make the cut. Straight, bevel, miter, and compound cuts can be made.

Crosscutting Safety

The hazards associated with crosscutting include: exposed blade teeth, rolling carriage, and thrown workpiece. This section explains these hazards and tells how to avoid them or reduce the risk of their happening. **Read this section before making any type of crosscut. Follow these steps every time you make a crosscut.**

Exposed Blade Teeth

WARNING

During crosscutting, blade teeth can be exposed. To reduce risk of having fingers, hand or arm cut off:

- ✓ Correctly install and use guard.
- ✓ Lower pawls or riving knife to clear fence or workpiece, whichever is higher, by 1/4". Lowered pawls or riving knife act as partial barrier to front of blade.
- ✓ Keep hands away from blade and out of blade path. Keep hand holding down workpiece at least 8" from blade.
- ✓ Blade can come off table edge beyond 30° left miter position. Use right miter position whenever possible.
- ✓ Do not cut freehand. You will not be able to control workpiece.
- ✓ If blade jams, turn off saw, remove yellow key, then free blade.

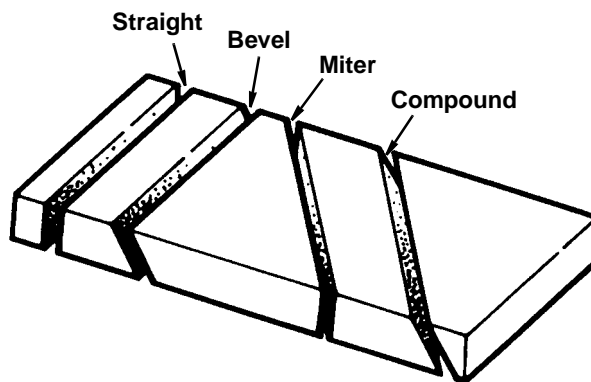

Rolling Carriage

WARNING

When saw is turned on, blade can suddenly come forward. To reduce risk of this happening:

- ✓ Keep one hand on saw handle when turning saw on.
- ✓ Adjust leveling feet to make sure radial arm slants slightly toward rear.

Thrown Workpiece

CAUTION

Workpiece could be picked up by spinning blade and thrown. You might be hit by thrown workpiece. To reduce risk of thrown workpiece:

- ✓ Make sure installed fence is at least half as high as the workpiece, and never less than 3/4".
- ✓ Start and finish cut with blade in rearmost position, behind fence.
- ✓ Firmly hold workpiece flat on table and up against fence. Cut only one workpiece at a time.
- ✓ Pull blade through workpiece only far enough to complete cut, and never more than half the diameter of blade.
- ✓ Do not touch or move workpieces until blade has stopped spinning.
- ✓ Use length stop only on end of workpiece which is held down.
- ✓ Use table extensions to support workpieces that extend beyond table.

Crosscut Kerfs

A kerf or shallow cut is needed in the table and fence to serve as a path for the blade and to ensure that the blade cuts all the way through the workpiece. A **kerf is needed for each different cutting path.**

To make an approximately 1/16" deep kerf:

1. Prepare table:
 - put fence in front position
 - tighten table clamps
2. Prepare blade:
 - lock motor in crosscut position
 - lock radial arm at desired miter angle
 - lock motor at desired bevel angle*
 - unlock carriage lock and push blade to rearmost position, behind fence
 - lower blade* to just clear table
 - lower pawls or riving knife to clear fence by 1/4".

** raise clear plastic guard before changing bevel angle and when lowering beveled blade, otherwise it may jam into table.*

3. Grasp saw handle, then turn saw on. **Keep one hand on saw handle through step 6.**
4. Slowly lower blade until it touches table, then lower one more full turn of crank.
5. Squeeze handle trigger to fully raise clear plastic guard so it will clear fence. Pull blade through fence and across table as far as it will go.
6. Push blade to rearmost position, behind fence, and turn saw off. Keep hand on saw handle until blade stops spinning.

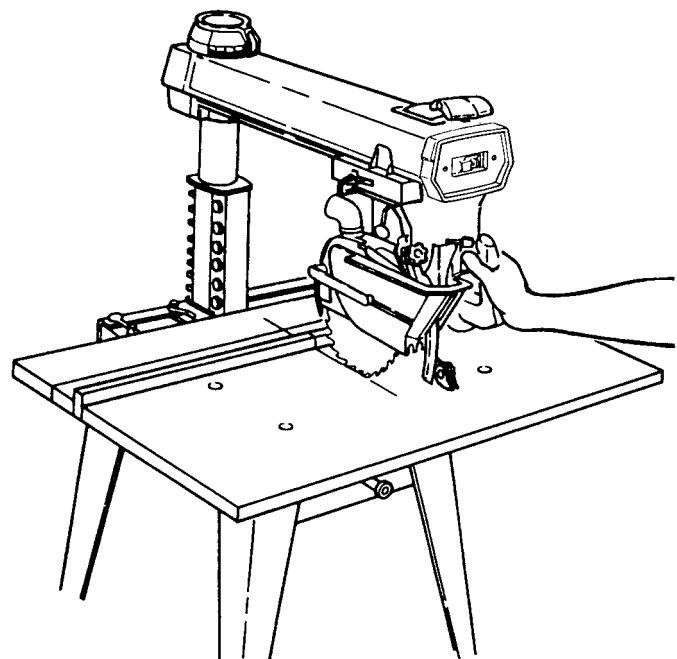
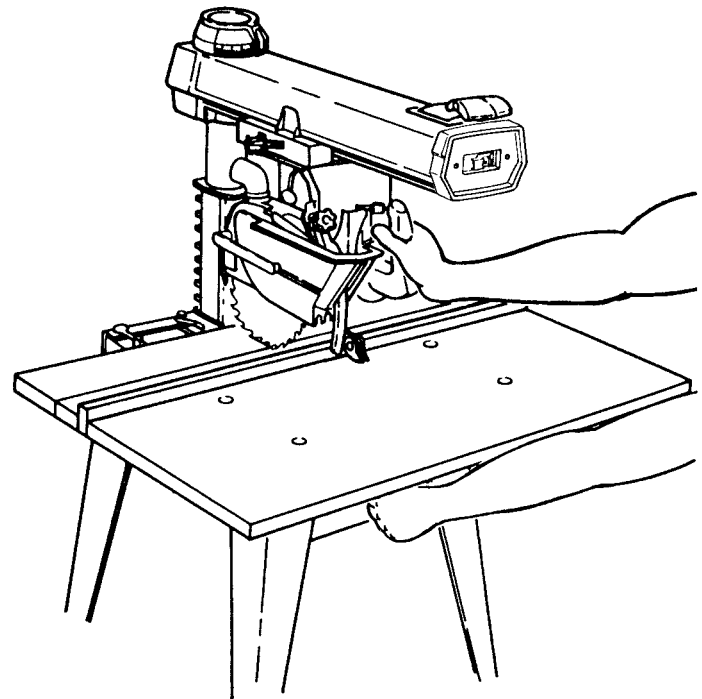

Crosscutting

Making Crosscuts

Follow these steps to make crosscuts.

1. Prepare table:
 - put fence in front position
 - tighten table clamps
2. Prepare blade:
 - lock motor in crosscut position
 - lock radial arm at desired miter angle
 - lock motor at desired bevel angle*
 - unlock carriage lock and push blade to rearmost position, behind fence
 - lower blade into kerf* but not touching kerf bottom (blade should move freely).

** raise clear plastic guard before changing bevel angle and when lowering beveled blade, otherwise it may jam into table.*

3. Position workpiece against fence, and lower pawls or riving knife to clear fence or workpiece, whichever is higher, by 1/4".
4. Grasp saw handle, then turn saw on.
Keep one hand on saw handle through step 7.

5. Hold workpiece down and against fence. Keep hand at least 8" away from blade.
6. Squeeze handle trigger to fully raise clear plastic guard so it will clear fence and workpiece. Pull blade through workpiece but only far enough to complete cut, and never more than half the diameter of blade.
7. Push blade carriage to rearmost position, behind fence, and turn saw off. Keep hand on saw handle until blade stops spinning.

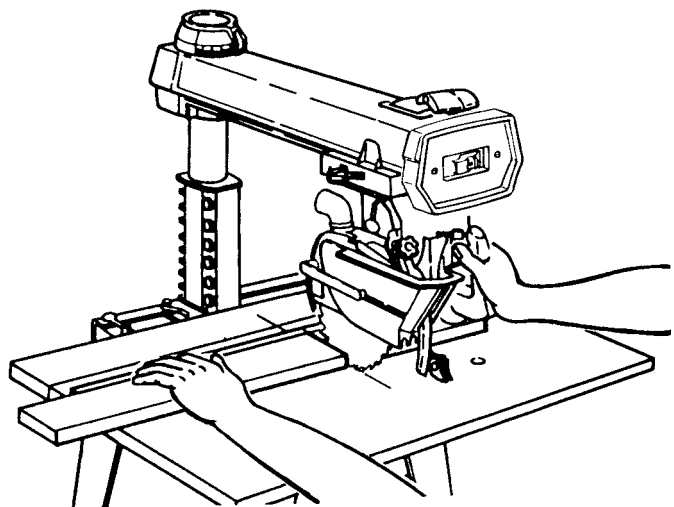
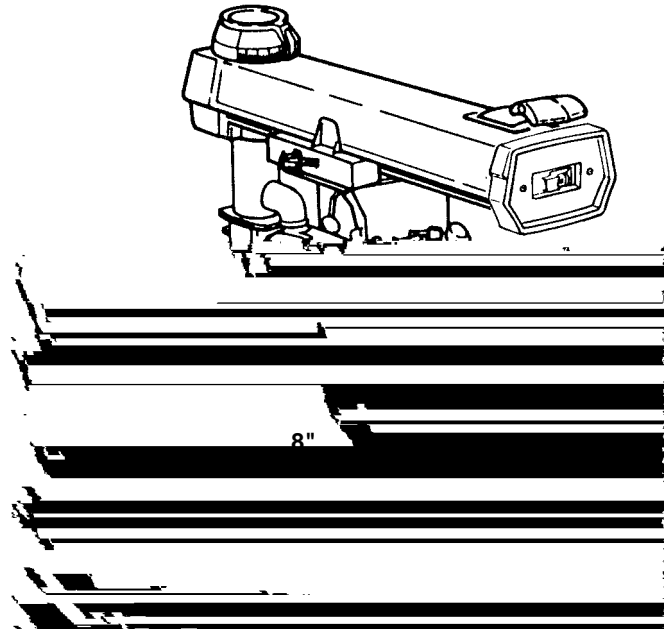

Repetitive Crosscutting

Repetitive crosscutting is the repeated and continuous cutting of many pieces of lumber to the same length. Carriage and length stops can help make this type of crosscutting more efficient.

A carriage stop defines the distance needed to pull the blade through to complete each cut. This will prevent pulling the blade through more than the recommended distance.

To make a carriage stop use 1x2 lumber:

- a) cut two pieces, each 2" long
- b) clamp a piece on each side of radial arm, so blade carriage stops at distance needed to complete cut
- c) check that clamps do not interfere with hand grip on saw handle.

A length stop defines the cut length and ensures that all pieces will be cut to the same size. Clamp a piece of 1x2 lumber on the fence to define the cut length. **Use a length stop only on the end of the workpiece which is held down.**

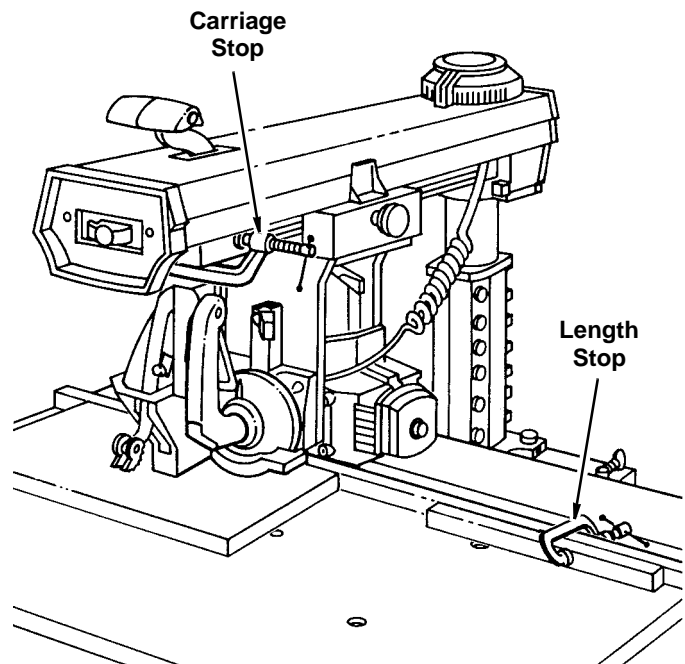

Crosscutting Hints

1. To extend life of table top, buy auxiliary table cover (see Accessories) or make one out of 1/4" plywood or fiberboard. Clamp or nail to original table top, section by section. If you use nails, nail in the four corners to make sure blade will not contact nails.
2. Make several fences, so each will have only a few kerfs (See Cutting Aides). Too many kerfs will weaken a fence.
3. Keep table clean of chips and sawdust.
4. Use sharp blades, and use the right blade for each job.
5. When making miter or bevel cuts, use extra force to hold workpiece down because it tends to move during these types of cuts.
6. When cutting hard woods, like oak, or making compound cuts, keep arm holding saw handle rigid and pull blade through slowly.
7. To keep cut line accurate, periodically check blade alignment.
8. Do not cut severely warped, bowed or twisted workpieces.

Ripping

Ripping Defined

Ripping is changing the width of a workpiece by cutting along its length. The workpiece is fed into the blade, which rotates in a fixed position, parallel to the fence and a set distance from the fence. A solid fence (no kerfs) serves as a guide for the workpiece. Place the fence in the front position for narrower workpieces, or in the rear position for wider ones.

In-Rip and Out-Rip Positions

In-rip and out-rip refer to blade position.

In-rip: the blade is toward the column, and the motor is toward the table front. In-rip is recommended because this position allows better visibility of the workpiece and your hands. Use in-rip when you set the blade 1/2 to 16" from the fence.

Out-rip: the blade is toward the table front, and the motor is toward the column. Use out-rip only when you set the blade 16" or more from the fence.

Infeed and Outfeed Directions

Infeed and outfeed refer to sides of the blade.

Infeed: the side of the blade where the guard hold down is. **Always start a rip cut at the infeed side and push the workpiece through to the outfeed side.**

Outfeed: the side of the blade where the pawls and riving knife are. **Never start a rip cut at the outfeed side. This is wrong way feed. Never put hands on the outfeed side of the blade when ripping because they can be pulled back into the spinning blade.**

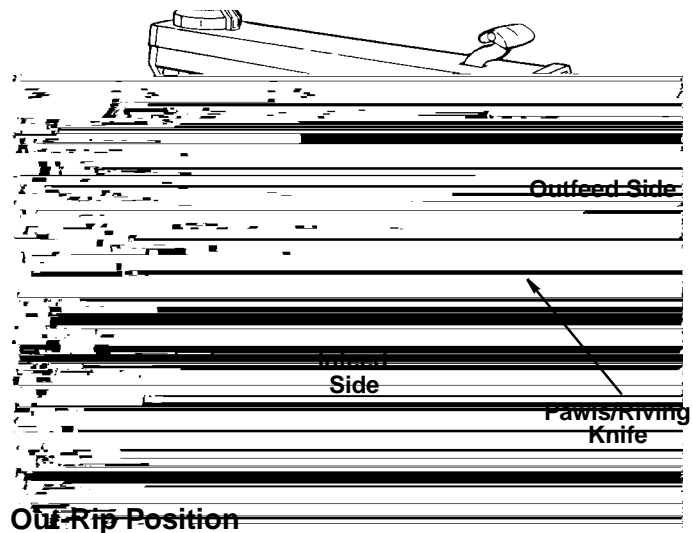
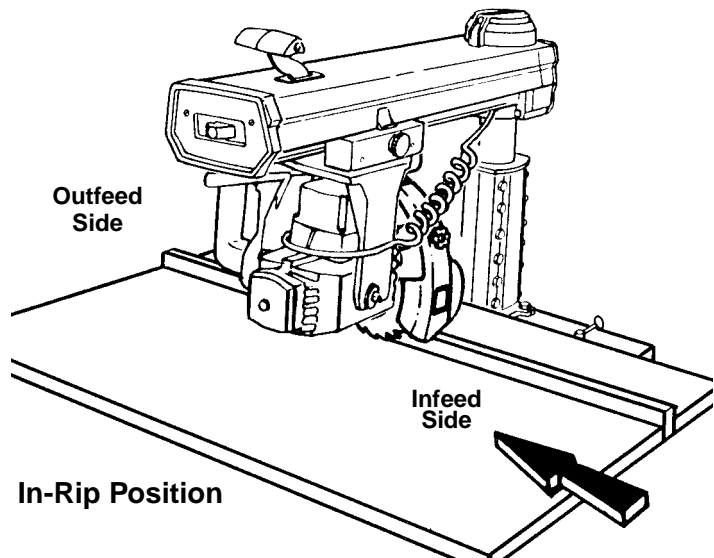
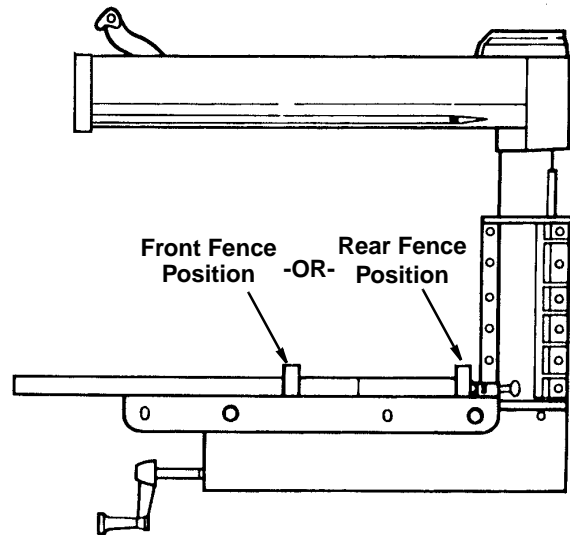

Workpiece Positioning

Always set up so that the wider part of the workpiece is between the blade and fence. This gives you greater clearance for push sticks, and allows better stability for feeding the workpiece.

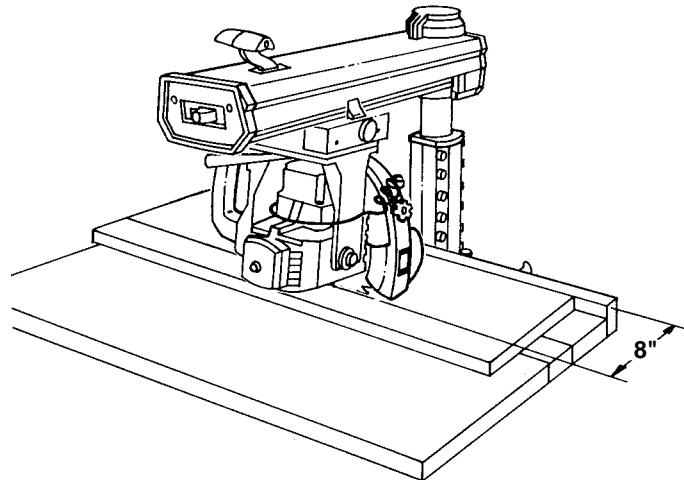

Example: To rip 2" off a 10" wide board, set blade in in-rip position 8" from rear fence.

Push Sticks and Push Blocks

Use push sticks and push blocks instead of the hands to push the workpiece through to complete cuts. They help keep hands away from the blade. A push block is used with an auxiliary fence. (see Cutting Aides).

Use a push block and auxiliary fence when the blade is set 1/2 to 2" from the fence.

Use a **push stick** when the blade is set 2" or more from the fence.

Do not set the blade closer than 1/2 " to the fence. The radial saw is the wrong tool for such a narrow cut. A band saw would be more appropriate for this type of cut.

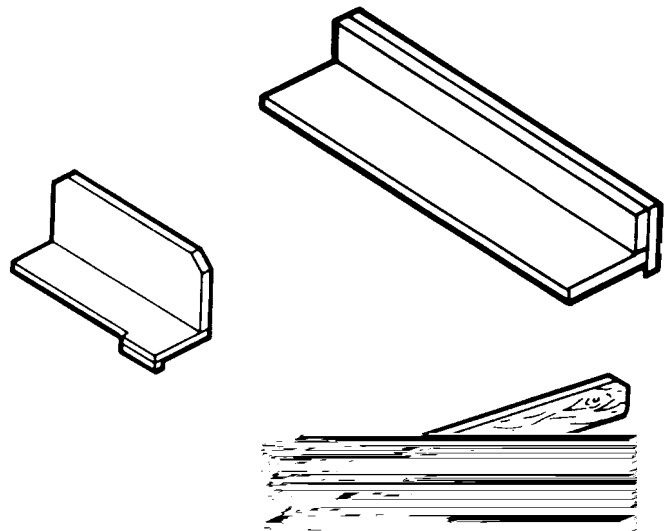

Ripping Safety

The hazards associated with ripping include: outfeed zone hazard, kickback, and wrong way feed. This section explains these hazards and tells how to avoid them or reduce the risk of their happening. **Read this section before making any type of rip cut. Follow these steps every time you make a rip cut.**

Ripping

Outfeed Zone Hazard

DANGER

Rotational force of blade can pull hands and fingers back into blade. Touching, holding, or pulling on outfeed side of workpiece while blade is still spinning will result in fingers, hand or arm being cut off. To reduce risk of outfeed hazard:

- ✓ Set pawls and riving knife; they act as partial barrier to outfeed side.
- ✓ Start and finish cut from **infeed** side.
- ✓ Keep both hands on infeed side.
- ✓ Keep hands away from outfeed side.
- ✓ Push workpiece through to complete cut. Do not reach around to pull it.
- ✓ If blade jams, turn saw off, remove yellow key, then free blade.

Kickback

Kickback is the uncontrolled propelling of the workpiece back toward the user.

WARNING

Kickback can happen when blade is pinched or bound by workpiece. Pinching or binding can happen when:

- pawls and riving knife are not used or not set correctly
- riving knife is not aligned with blade
- blade is not parallel to fence
- workpiece is twisted or warped and rocks on table top
- pressure is put on outfeed side of workpiece
- workpiece is released before being pushed past pawls
- user touches or tries to pull workpiece through outfeed side before blade has stopped spinning.

DANGER WHEN RIPPING

<ol style="list-style-type: none">1. Read and understand owner's manual before operating machine.2. Wear safety goggles complying with ANSI Z87.1.3. Keep hands out of path of saw blade.4. Know how to avoid "KICKBACKS".	<ol style="list-style-type: none">5. Use "PUSH STICK" for narrow work.6. Never reach around the saw blade.7. Never perform any operation "FREEHAND".8. Shut off power and allow saw blade to stop before adjusting or servicing.
---	---

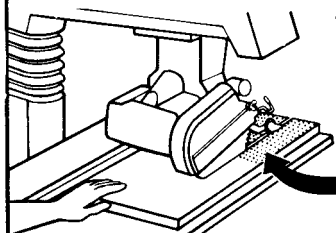

TO AVOID RUNAWAY WORKPIECE
ALWAYS PUSH WORKPIECE into cutting tool FROM THIS END ONLY

DANGER AT OUTFEED
Workpiece can suddenly kick back and pull hands into and under cutting tool

OUTFEED DANGER ZONE SHADED KEEP HANDS AWAY!

MOTOR: 120/240 VOLTS 11.0/5.5 AMPS 3450 R.P.M. 60 Hz 1 PHASE

WARNING



KICKBACK

Set hold down, pawls and spreader.

Stand out of workpiece path.

To reduce risk of kickback:

- ✓ Set pawls and riving knife according to ripping set-up procedure. Correctly set riving knife is more likely to prevent workpiece from binding or pinching blade; correctly set pawls are more likely to grab into workpiece to stop or slow kickback if one happens.
- ✓ Check that riving knife is in line with blade (see Alignment: Riving Knife to Blade).
- ✓ Cut only straight workpieces so surface will lie flat on table and edge will stay tight against fence. If you must cut an irregular workpiece, attach a straight edge (see Cutting Aides).

- ✓ Push workpiece through from infeed to outfeed side until it is completely past pawls.
- ✓ Use featherboard (see Cutting Aides).
- ✓ Keep hands away from outfeed side.
- ✓ If blade jams, turn saw off, remove yellow key, then free blade.
- ✓ When cutting composition materials, or other materials with one smooth and one rough side, put rough side up so pawls will be more likely to grab.

Wrong Way Feed

Wrong way feed is ripping by feeding the workpiece into the outfeed side of the blade.



WARNING

Rotational force of blade will pull workpiece through violently if workpiece is fed in same direction as blade rotates (wrong way feed). Hands and fingers could be pulled along with workpiece into spinning blade before you can let go or pull back. Fingers, hand or arm could be cut off. Propelled workpiece could hit bystander.

To eliminate risk of wrong way feed:

- ✓ Feed workpiece against blade rotation.
- ✓ Set pawls and riving knife; they act as partial barrier to outfeed side.



Hold Down Function

The hold down must be set correctly during ripping to act as barrier against the infeed side of the blade, to help keep the workpiece flat on the table, and to deflect workpiece chips. It must be lowered to just clear the workpiece.

The hold down must be ree12(c l.)JTJ 0 -)12(e)-11(t)8(a)1(b)23(()1m)-7(t)8(a)10(t)- TD 0.002 Tw (chi)7(at)8

Ripping Set-up Procedure

Follow these steps **before** ripping.

These steps must be repeated each time a different thickness workpiece is ripped. A kerf must be made for each different width cut. Also see the special notes for bevel set-up that follow this section.

1. Prepare table:
 - insert solid (no kerfs) fence (**Note:** *Use auxiliary fence when blade is set 1/2 to 2" from fence (See Cutting Aides)*)
 - tighten table clamps.
2. Prepare blade:
 - lock radial arm at 0° miter - lock blade in in-rip position*
 - lower blade to just clear table
 - lock blade carriage desired distance from fence. **Note:** *Make sure wider part of workpiece will be between blade and fence.*

* use out-rip position for rips 16" or wider

3. Make kerf:
 - a) turn saw on
 - b) lower blade about 1/16" into table
 - c) turn saw off and remove yellow key.
4. Place workpiece parallel to and up against blade.** **Note:** *Workpiece will be between blade and table front.*
5. Lower hold down** to workpiece, then raise slightly so it just clears top surface of workpiece. Lock in place.
6. Lower riving knife to table. **Lower** pawls to workpiece surface.** **Move** workpiece toward outfeed side until one set of pawls rests level on workpiece surface. Lock in place.

** *bevel set-up: see special notes, next page*

WARNING

If workpiece is pushed along fence with kerfs, workpiece could get caught on kerf, pinch blade and cause kick-back. Do not use crosscutting fence for ripping.

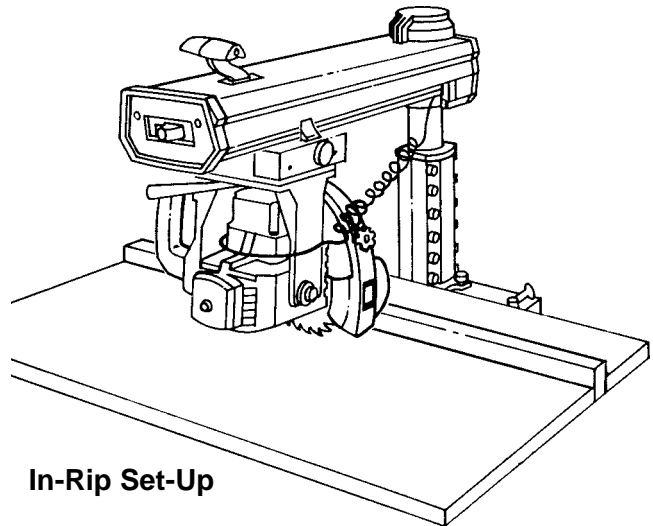

In-Rip Set-Up

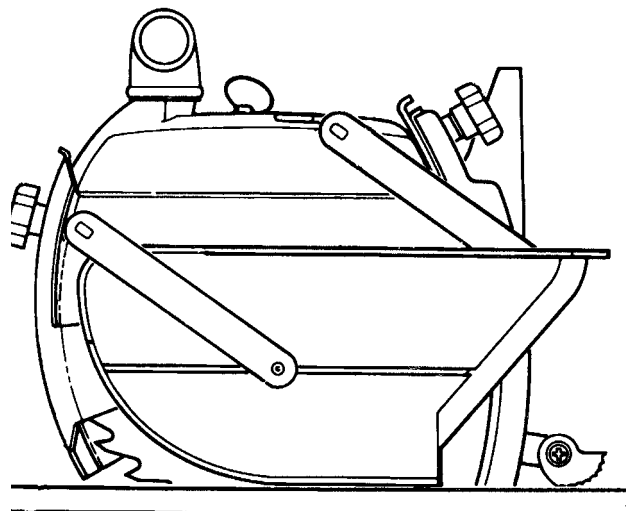

Setting Guard For Rip Cut

Ripping

7. Remove workpiece from table.
8. Ready push stick or push block.
9. Set up table extension(s) and support their outer ends. **Do not use another person to support workpieces because this can cause kickback and it exposes helper to potential hazards at outfeed side.**

Special Notes for Bevel Set-Up



CAUTION

Bevel ripping creates unique problems of visibility and feeding. Before cutting, check the set-up using both in-rip and out-rip. Use the position that gives the best combination of workpiece visibility and push stick clearance.



WARNING

Bevel the edge that is not against the fence.

1. When setting bevel angle, raise radial arm to allow sufficient clearance for blade and guard to not jam in table.
2. When blade is beveled manually raise clear plastic guard before lowering blade to table or kerf, otherwise it may jam in the table.
3. To set hold down, place workpiece directly under guard nose, rather than parallel to blade.
4. To set pawls, place workpiece directly under set of pawls closer to table. This set of pawls will keep contact with workpiece surface.

Making Rip Cuts

Follow these steps to make in-rip cuts. For out-rip cuts, reverse hand functions; that is, put right hand on table and use left hand to support and push workpiece.

1. Follow ripping set-up procedure.

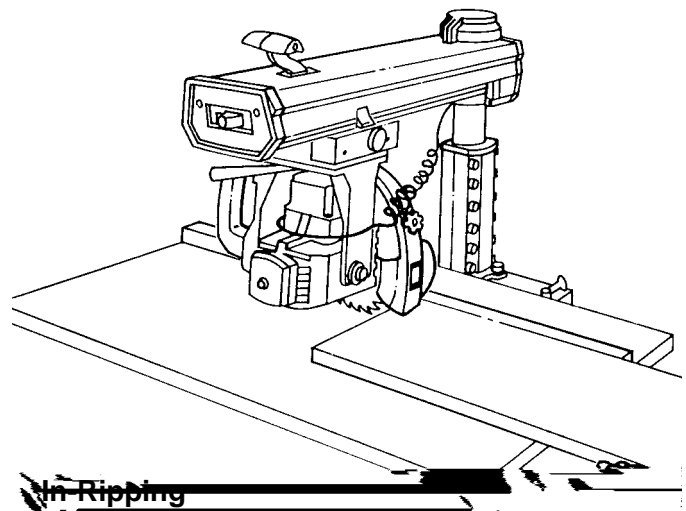
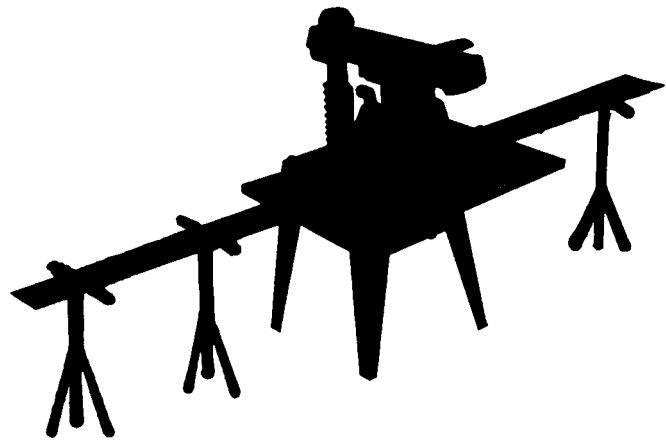

2. Insert yellow key and turn saw on.
3. Stand at infeed side and out of line of workpiece, in case of kickback. **Start and finish cut from infeed side.**
4. Put workpiece on table, in front of hold down, and tight against fence. To hold workpiece in position, put left hand on table, at least 8" in front of hold down, and lightly press fingers against workpiece. Support workpiece with table extension or right hand.



CAUTION

For large workpieces use a feather board in place of your hand on the table. It gives better support. (See cutting aides)

5. With right hand, push workpiece under hold down and into blade. Keep left hand fixed on table, applying slight pressure to keep workpiece against fence.
6. Use right hand to continue to apply feed pressure to part of workpiece close to fence. Keep hand at least 8" in front of hold down.
Note: Most workpieces will automatically raise clear plastic guard as they pass from infeed to outfeed side. Unusually tall and narrow workpieces may not raise clear guard. When this happens, push guard tab to raise guard, then release tab when guard rests on top of workpiece surface.



CAUTION

Pushing guard tab means using only one hand to control workpiece. While pushing tab, use extra care to guide workpiece and to keep hand at least 8" in front of hold down.

Release tab as soon as clear guard rests on workpiece.

7. When end of workpiece gets to table, use push stick or block, instead of hand, on part of workpiece between blade and fence to push until workpiece is completely past pawls.
8. Turn saw off and **wait for blade to stop spinning before touching workpiece.**

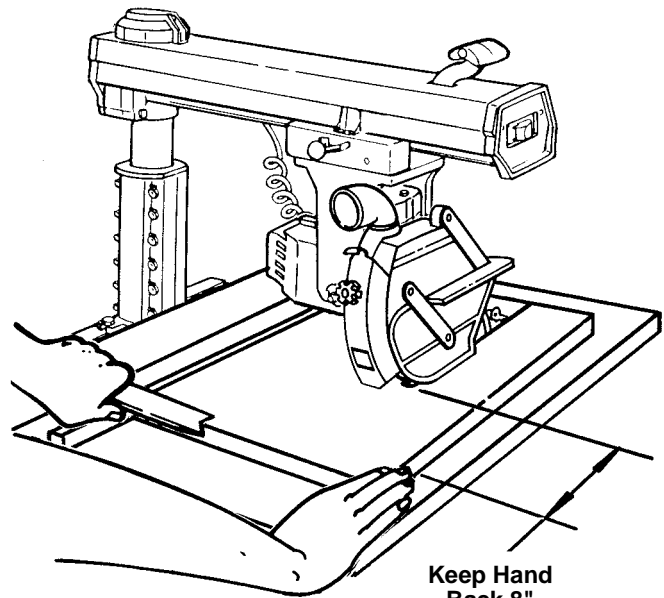

Out-Ripping

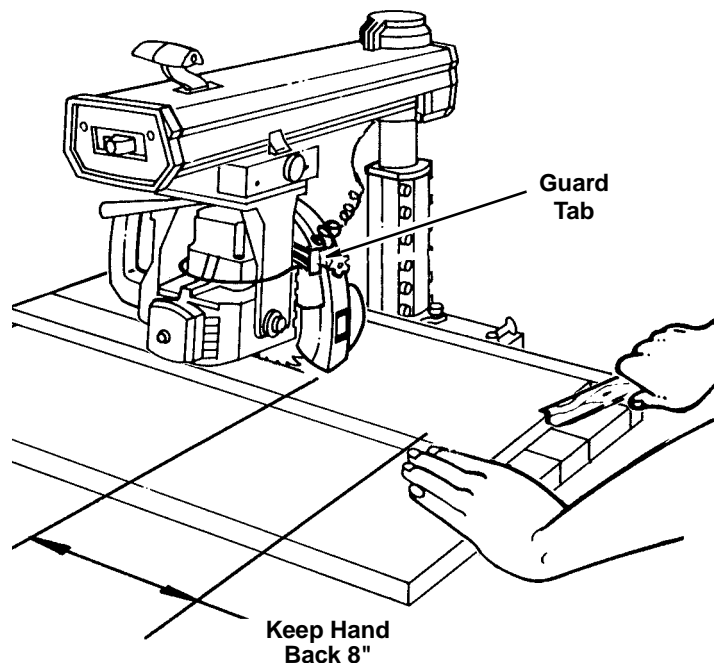

In-Ripping

Ripping

Dado Blades, Molding Heads

See Accessories for information on safety, installation and use of dado blades and molding heads.

Edging

Edging is the use of a dado blade or molding head in the horizontal position. It is an advanced technique that requires a molding head guard and a special fence. See Accessories for information on safety, installation and use of dado blades and molding heads for edging. See Cutting Aides for information on making the special fence.

Ripping Hints

1. To extend life of table top, make auxiliary table cover out of 1/4" plywood or fiberboard. Clamp or nail to original table top, section by section. If you use nails, nail in the four corners to make sure blade will not contact nails.
2. Keep table clean of chips and sawdust.
3. Use sharp blades.
4. Use the right blade for each job.
5. For workpiece with one smooth and one rough surface, such as paneling or finished fiberboard, cut with rough surface up so pawls will be more likely to grab in case of kickback.
6. To keep cut line accurate, periodically check blade alignment.
7. If you must cut an irregular workpiece, attach a straight edge (see Cutting Aides).

DANGER

Edging without a guard could bring hands and fingers too close to cutting tool.

Hands, fingers, and arm could be cut off.

- buy, install, and follow instructions for molding head guard
- use only dado or molding head for edging
- do not use blade because blade cannot be guarded when horizontal
- read and follow instructions in Accessories section of manual.

Cutting Aides

Before cutting any wood on your saw, study all of the Crosscutting and Ripping Instructions found on pages 45 through 57. As you learn new radial arm saw woodworking techniques, you'll see that many types of cuts need different support and feeding devices, known as jigs or fixtures. They can help you make cuts more accurately. By helping to steady the workpiece and keep you away from the blade, they can help you safely use your saw for certain cuts. Many people custom build their own jigs and fixtures. Jigs and fixtures are often designed for a particular cut. You can use your radial saw to easily make many jigs and fixtures. To get you started, we've included instructions for some simple ones. After you have made a few practice cuts, make up these jigs before starting any projects. Make the push stick first.

Push Sticks

Make the push stick using a piece of 1 x 2. (see drawing top right for dimensions and shapes)

Push Block

There are any number of ways to properly cut your work pieces to make a push block. The following steps describe one way you can proceed.

Making the base:

- Start with a piece of 3/8" plywood at least 5-5/8" wide or wider and 12" long or longer.
- Make two ripcuts. Perform the first ripcut along the long side of the 3/8" plywood to create a 3/8" wide strip. Next ripcut the 3/8" plywood to a width of 5-1/8".
- Crosscut the 3/8" plywood to 12" long.
- Crosscut a 2-1/2" piece off of the 3/8" wide by 3/8" thick strip and save this short piece for later.
- The next cuts will create the 3/8" by 9-1/2" notch in the base. Mark the long edge of the board 2-1/2" from one end. Make a crosscut into the edge, stopping about 3/4" into the board. Set the saw to the in-rip position and rip the width to 4-3/4" along the same edge as the stopped crosscut. Stop the ripcut where the two cuts intersect. Turn off the saw and remove the base piece. The base should now measure as shown.

Push Stick

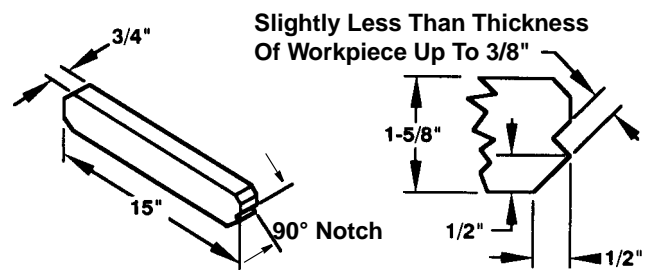

Material for Push Block

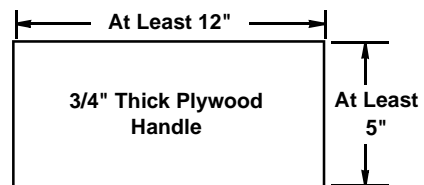
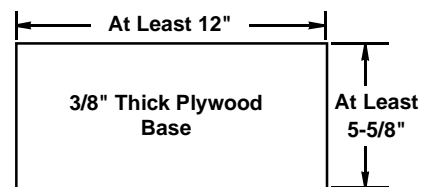

Cutting Out the Base

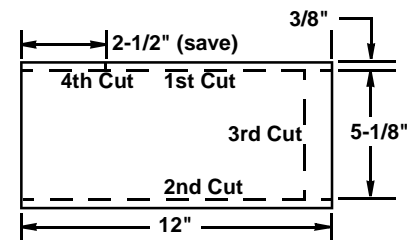

Creating the Notch

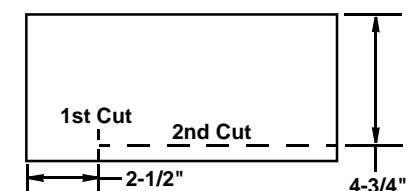

Finished Base

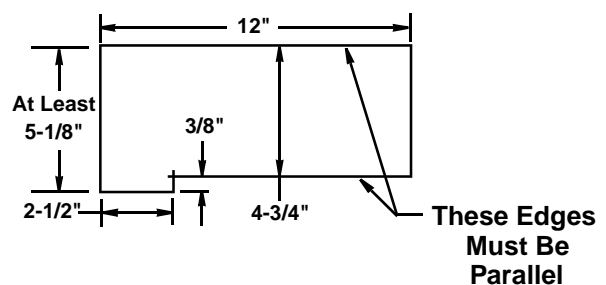

Making the Handle:

- Miter crosscut a piece of 3/4" thick plywood to the shape and size shown. The mitered corners can be any size that looks like the drawing (about 1-1/2" by 1-1/2").

Putting it together:

- Using good quality wood working glue, glue the 2-1/2" strip saved earlier to the base as shown. **Important:** Do not use nails or screws. This is to prevent dulling of the saw blade in the event you cut in to the push block.
- Position the handle at the edge of the plywood base as shown. Fasten them together with glue and wood screws. **Important:** Make sure the screw heads do not stick out from the bottom of the base.

Clamp the featherboard to the front table, so that the angled edge of the featherboard is against the workpiece on the infeed side of the blade. **Do not clamp the featherboard against the cut off part (out-feed side) of the workpiece.** If clamped to the outfeed side, the featherboard can squeeze the kerf closed, put binding pressure on the blade, and cause kickback.

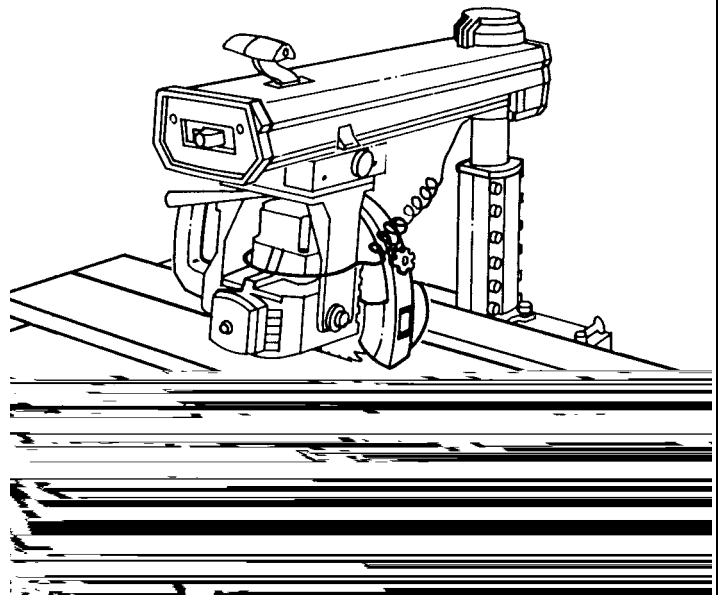

Straight Edge for Irregular Workpiece

WARNING

If you try to rip an irregular workpiece, it could bind blade and cause kickback.

If the workpiece you want to rip does not have a straight edge, attach a straight-edged board to the workpiece:

- a) place irregular side of workpiece against fence
- b) put straight-edged board on top of workpiece and against fence
- c) tack straight edged board to work piece.

Note: *Straight-edged board must not extend beyond leading end of workpiece and should cover workpiece width only enough to pass between blade and fence.*

Note: *Use fence at least as high as combined heights of workpiece and straight-edged board.*

Maintenance

Replacing Pawls

Make sure the teeth of the pawls are always sharp. If they become dull the pawls must be replaced:

1. Use 7/16" wrench to remove hex nut. Remove old pawls.
2. Install new pawls. Place spacers exactly as shown.
3. Re-install hex nut.
4. Check that pawls work freely.

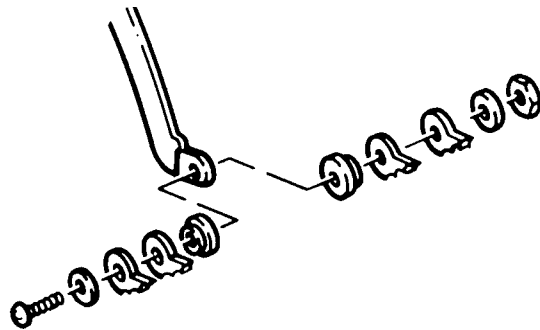

Lubricating Blade Guard Assembly

If guard becomes difficult to raise:

1. Clean sawdust from the slot and slider.
2. Regrease with a small amount of light grease applied to the slot and slider. Also add a thin coat of grease between the Trigger and the Pull Link.

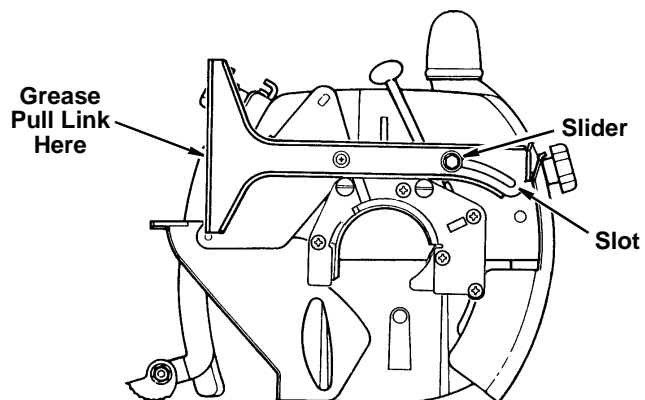

Adjusting the Trigger

If the trigger becomes loose side-to-side, adjust the setscrews at the top of the yoke handle. Use a 1/8" hex wrench to tighten setscrews tight. Then back off one setscrew until the trigger moves freely.

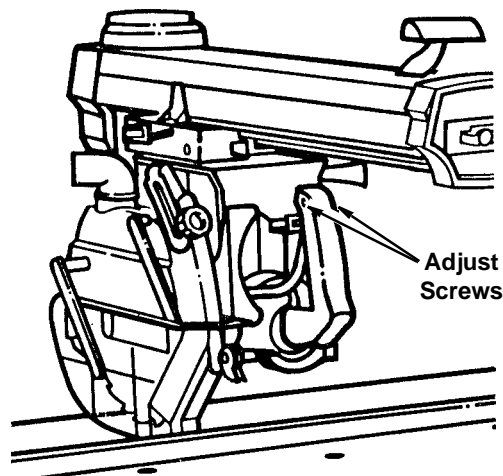

**PARTS LIST CRAFTSMAN 10" RADIAL SAW GUARD KIT
No. 509347**

Always order by Part Number - Not by Key Number

FIGURE 1

Key No.	Part No.	Description
1	820985	Guard Accessory
2	805548-10	Washer 3/16 x 1/16
3	STD610805	* Screw Plastite #8 x 1/2
4	SP6311	Form Instructions
5	803425	Screw, Locking Set 1/4-20 x 3/8
6	821354-1	Trigger
7	STD601103	* Screw Pan Hd Ty "T" 10-32 x 1/2
8	821410	Handle, Hoke Asm
9	818169	Table Rear 40"
10	820573	Table Spacer 40"
11	824980	Table Front 40"
12	37384	Nut, Tee
13	818199	Table Support
14	826284	Clamp Assembly
—	SP5984	Owners Manual (Not Shown)

* Standard Hardware Item - May be purchased locally.

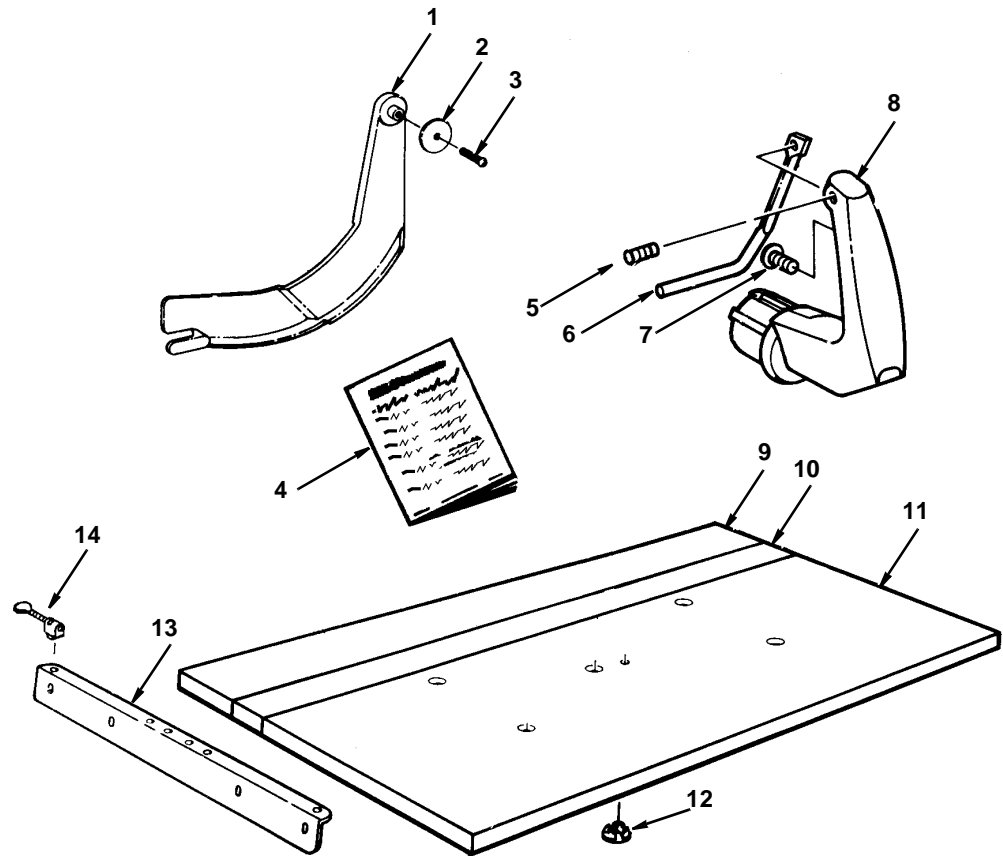

Repair Parts

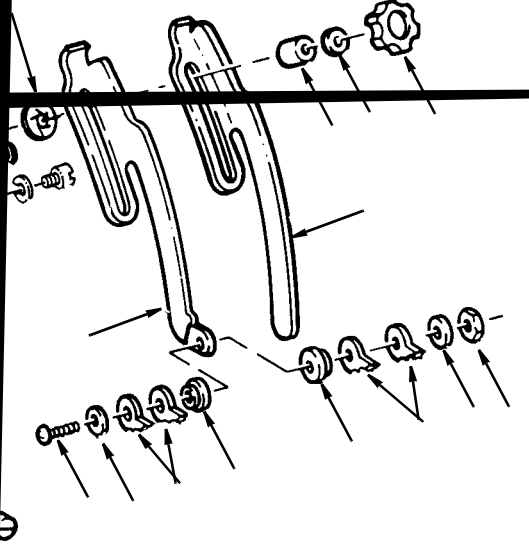
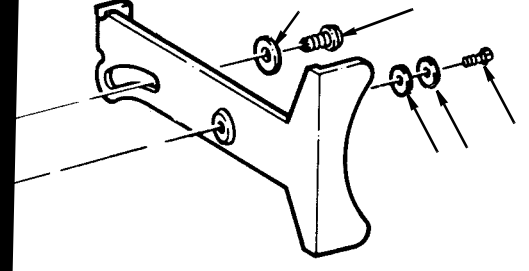

PARTS LIST CRAFTSMAN 10" RADIAL SAW GUARD KIT

No. 509347

Always order by Part Number - Not by Key Number

FIGURE 2

Key No	Part No.	Description
1	821217	Screw, Guard Clamp
2	821313	Link, Pull
3	STD551025	* Washer, 17/64 x 5/8 x 1/16
4	815865	Screw, Hex Washer Hd Type "TT" 1/4 - 20 x 1/2
5	STD601105	* Screw, Pan Hd Type "TT" 10-32 x 5/16
6	802392-47	Spacer #10 x .125
7	808447-6	Washer, Spring
8	827919	Knob, 5/16-18
9	STD551031	* Washer 21/64 x 5/8 x 1/16
10	820521	Spacer
11	820515	Knife, Riving
12	STD541425	* Nut, Lock 1/4-20
13	815815	Pawl, AKB
14	820517	Bushing
15	STD512510	* Screw, Pan Hd. 1/4-20 x 1
16	820512	Holder, AKB
17	824159	Screw, Flat Hd Type "TT" 1/4 - 20 x 9/16

Key No.	Part No.	Description
18	820519	Nut, Slotted 1/4 - 20
19	STD551225	* Lockwasher 1/4
20	820530	Support, Knife
21	808822-1	Nut, Push 1/4
22	820632-3	* Ring, Retaining
23	STD533107	* Bolt, R.H. Short Neck 5/16 - 18 x 5/8
24	809019-4	Bolt, Rd Hd Short Neck 5/16 - 18 x 1-3/4
25	820532	Bolt 1/4-20 x 1/2
26	821310	Guard, Lower
27	821311	Link
28	821312	Guard
29	821314	Hold Down
30	828139	Elbow, Dust
31	60413	Nut, Push 5/16
32	821449	Nut, Square 5/16 - 18 Double Lead
33	824158	Strap-Retainer
34	825756	Screw Guard Index
35	STD551131	* Lockwasher

* Standard Hardware Item - May Be Purchased Locally

owner's
manual

MODEL NO.
509347

10-INCH RADIAL SAW GUARD KIT

For Customer Service Questions
or Replacement Parts Call

1-800-325-1184

NOTE:

1. This manual is intended to be used along with your original saw manual. If you no longer have your saw's owners manual, call customer service at 1-800-325-1184. Have your saw's model number when you call.

2. If you require this manual in Spanish or French, call 1-800-511-2628.

Si usted requiere que este manual usuario en español o francés, llame 1-800-511-2628. Pedir formulario SP5984S-2.

Si vous nécesstent ce mode d'emploi en espagnol ou français, téléphonez au 1-800-511-2628. Demander pour forme SP5984F-2.